



# MTJP12.5

Vertical mast lift

## STANDARD EQUIPMENT

- Horn
- Emergency stop button
- Emergency lowering system
- On-board diagnostics system
- Hour counter
- Proportional controls
- Permissible side-shift at maximum height
- Automatic braking system
- Tilt indicator with alarm
- Movement alarm sensor
- Charger protection
- Platform load moment indicator
- Flashing light



LOGISTICS



CONSTRUCTION

## MTJP12.5

Load capacity		200 kg
Max. occupants		2/1
Max. working height		12.40 m
Max platform height		10.40 m
Max horizontal outreach		5.50 m
Up and over height		7.00 m
Overall length	A	3.82 m
Overall width	B	1.20 m
Overall height	C	1.99 m
Platform dimensions (length/width)		0.69 m / 0.93 m
Ground clearance (stowed)		0.10 m
Ground clearance (raised)		0.015 m
Wheelbase	D	1.60 m
Turning radius (inside/outside)		0.70 m / 2.50 m
Turret rotation		345°
Jib movement		+60°/-60°
Driving motor		2x32VAC/2,0kW
Lifting motor		30VAC/5,0 kW
Travel speed (stowed)		4.5 km/h
Travel speed (rated)		0.5 km/h
Up\Down Speed		42 / 37 sec
Batteries		48V/200Ah Lead batteries maintenance-free
Integrated battery charger		48V/35A
Gradeability		25%
Maximum working slope (indoor use)		2.5° / 2.5°
Non-marking tyres		470x178 mm
Weight (CE)		4,920 kg

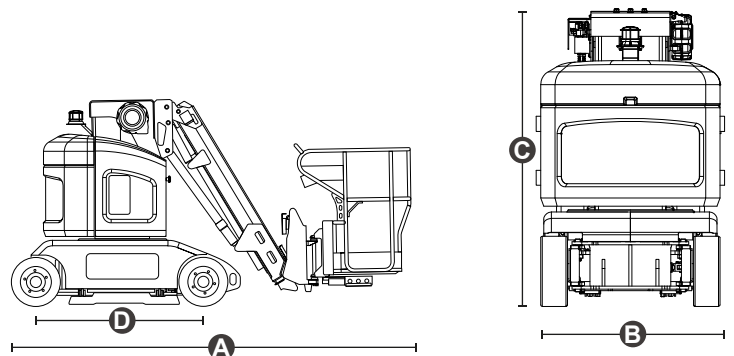

**STANDARDS MET:** EN 280-1, ANSI/SAIA A92.20

The data given in this brochure are provided for information purposes and are subject to change without prior notice. All images are purely guideline and might not give an exact representation of the product.