

**IN**
OUT**4WD****2WS**

MHTB20RT

Telescopic boom lifts



STANDARD EQUIPMENT

- Oscillating front axle
- Two travel speeds
- Two-wheel steering
- Four-wheel drive
- 360° rotation (continuous)
- Special construction equipment-grade integral driveshaft
- Proportional controls
- Thumb rocker steering
- Flashing light
- Non-marking tyres
- Horn
- Hour counter
- Harsh environment kits
- 12V DC Auxiliary power

ENGINE

- Stage V engine
- Auto-engine fault shutdown
- Anti-reverse engine device
- Anti-restart engine protection
- Hydraulic oil radiator

BASKET

- Self-levelling
- Rotation +/-90°
- Schuko power socket 16A/250 V

SAFETY

- Drive enable system
- Platform load moment indicator
- On-board diagnostics system
- Emergency lowering system
- Tilt indicator with alarm
- Crushing protection

**CONSTRUCTION****LOGISTICS**

LOAD CHART

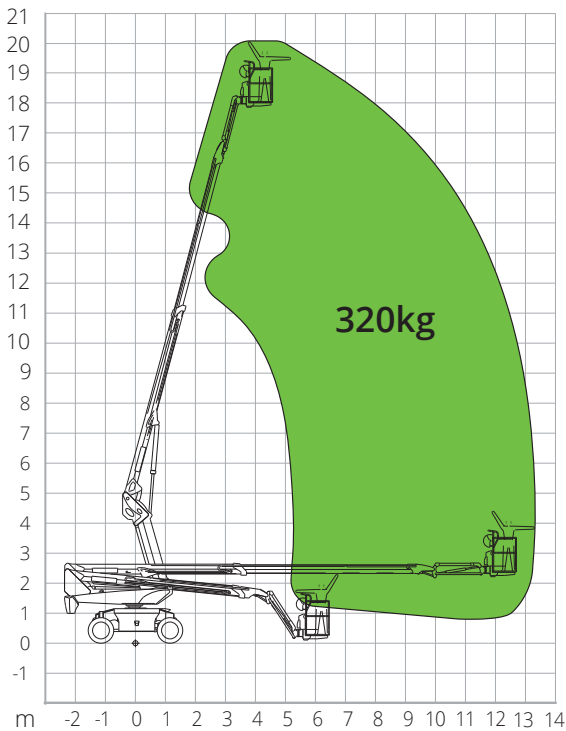

DIMENSIONS

Platform length (transport)		7.63 m
Platform width (transport)		2.44 m
Platform width (axle expanded)		-
Platform width (axle retracted)		-
Platform height (transport)		2.68 m
Wheelbase	B	2.40 m
Wheelbase (axle extended)		-
Wheelbase (axle retracted)		-
Tailswing		-
Ground clearance	A	0.31 m

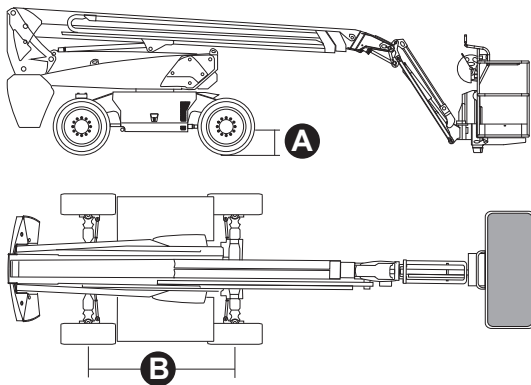

STANDARDS COMPLIANCE: EN 280-1, ANSI/SAIA A92.20

The data given in this brochure are provided for information purposes and are subject to change without prior notice. All images are purely guideline and might not give an exact representation of the product.

MHTB20RT

Technical data

Max. working height	20.23 m
Max. basket height	18.23 m
Max. reach	13.36 m
Turning radius (outside)	4.73 m
Turning radius (inside)	3.00 m
Basket width	0.79 m
Basket length	1.83 m
Basket rotation	180°
Jib type	Standard
Jib length	1.50 m
Jib Vertical Rotation	132°
Jib travel angle	-
Auxiliary power	12V DC

Performance

Platform max. load capacity	320 kg
Max. occupants	2
Max. gradeability (stowed)	40%
Max. working slope	X-5°/Y-5°
Max. wind speed	12.5 m/s
Travel speed (closed config.)	6.0 km/h
Travel speed (working config.)	1.1 km/h
Turret rotation (continuous)	360°

Engine

Power	Kubota D1 105/18.2 kW
Diesel tank capacity	115 l
Hydraulic tank capacity	145 l
Transmission	Hydrostatic

Total weight

8,150 kg

Specific characteristics

Tyres	315/55D20
Battery type	Lithium battery
Battery capacity	80VDC/67.5Ah