

ATTACHMENTS
RTH / TH / HTH

IF YOU DREAM IT, YOU CAN DO IT.

Riccardo Magni - Chairman & CEO

We build the future.

The future doesn't just happen; it has to be built, day by day. For Magni, the future has meant challenges, enterprise and innovation since 2013.

This vision, embedded in our brand's DNA, is expressed in a constant commitment to the research and development of new solutions and new technologies.

ATTACHMENTS

COLLECTION

PLATFORMS

Magni offers a wide range of platforms to offer safe access at any height. From standard models to highly specialised ones, we can provide the perfect solution for any application, whether in construction or large maintenance projects.

Section 1

FORK CARRIAGES

Ideally suited to even the most demanding applications, like quarries and mines, our fork carriages can handle any job even under extreme conditions. From simple fork carriages to heavy-duty units with oversized forks, we have the best solution to get the job done.

Section 3

WINCHES

Our winches offer unbeatable performance for effortlessly lifting and moving loads. Compact and robust, these first-class attachments offer Magni's hallmark quality in every detail.

Section 2

LATTICE BOOMS WITH/ WITHOUT WINCH

Precise and versatile, lattice booms are the ideal solution, whatever the job. They easily adapt to varying conditions, always offering the best solution to any problem.

Section 4

HOOKS

Simple and yet extremely versatile and durable, Magni type-approved hooks have a vast range of applications in construction. The range includes hooks of various load capacities in response to specific requirements, always with the best performance.

Section 5

BUCKETS

Developed for the construction and maintenance sectors, our buckets are available in a range of lifting capacities, and are known as reliable partners in any industrial application. Like all our attachments, they offer Magni's guaranteed performance and quality.

Section 7

CLAMPS

Designed specifically for mining and quarrying applications, as well as the logistics sector, our clamps offer unrivalled versatility and performance. The range has been specifically designed to handle even the toughest conditions.

Section 6

SPECIAL EQUIPMENT

This category covers our attachment range for specialised applications. From removing large trees to cleaning roads with snow ploughs or installing glass panels high up on tall buildings - Magni always has the best solution for specialised requirements.

Section 8

PLATFORMS



Magni offers a wide range of platforms to offer safe access at any height. From standard models to highly specialised ones, we can provide the perfect solution for any application, whether in construction or large maintenance projects.

Check the compatibility and capacity of each attachment with your dealer.



PLATFORM, 550 LB

ATT - 01 - 001

Fixed platform with a maximum load capacity of 550 lb, type-approved to carry two operators. Galvanised, reinforced steel structure. Non-slip floor for increased operator safety even in wet conditions.

CHECK FOR ANY PREARRANGEMENT REQUIREMENTS

P 1,4

			
550 lb	4'7" x 2'3"	2	✓





ROTATING PLATFORM, 550 LB

ATT - 01 - 003

Rotating platform (+/- 90°) with a maximum load capacity of 550 lb, type-approved to carry two operators. Galvanised, reinforced steel structure. Non-slip floor for increased operator safety even in wet conditions.

CHECK FOR ANY PREARRANGEMENT REQUIREMENTS

RP 1,4

				
550 lb	4'7" x 2'2"	+ / - 90°	2	✓







PLATFORM, 550 LB

ATT - 01 - 002

Fixed platform with a maximum load capacity of 550 lb, type-approved to carry two operators. Galvanised, reinforced steel structure. Non-slip floor for increased operator safety even in wet conditions.

CHECK FOR ANY PREARRANGEMENT REQUIREMENTS

PS 1,4				
				
550 lb	4'7" x 2'3"	×	2	×







ROTATING PLATFORM, 1,100 LB

ATT - 01 - 005

Rotating platform with a maximum load capacity of 1,100 lb, type-approved to carry three operators. Galvanised, reinforced steel structure. Non-slip floor for increased operator safety even in wet conditions. The platform is equipped with an overload sensor and rack with anti-shock system to ensure smooth, rotational movements when stopping and starting. The base of the platform is equipped with fork insertion points.

CHECK FOR ANY PREARRANGEMENT REQUIREMENTS

RP 2,2				
				
1,100 lb	7'4" x 3'9.5"	+ / - 90°	3	✓

EXTENDABLE ROTATING PLATFORM, 1,100 LB - 14' 9"

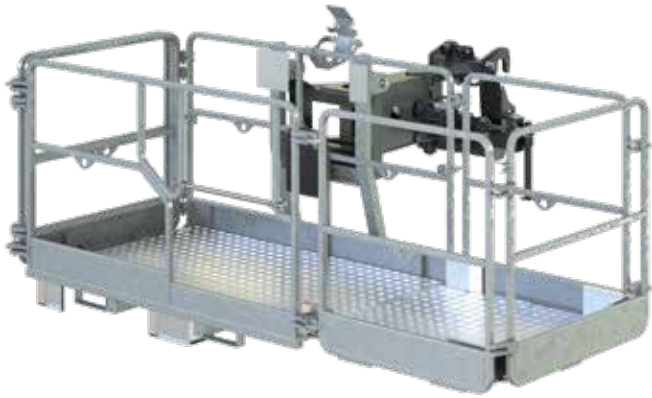





ATT - 01 - 007

Extendable rotating platform with a maximum load capacity of 1,100 lb, type-approved to carry three operators. Galvanised, reinforced steel structure. Non-slip floor for increased operator safety even in wet conditions. The platform is equipped with an overload sensor and rack with anti-shock system to ensure smooth, rotational movements when stopping and starting. An efficient patented extension system provides extra reach of 3'3" per side. The base of the platform is equipped with fork insertion points.

CHECK FOR ANY PREARRANGEMENT REQUIREMENTS

REP 2-4,5

				
1,100 lb	7'8" - 14'10" x 3'7"	+ / - 90°	3	✓

EXTENDABLE ROTATING PLATFORM, 1,100 LB - 18'0.5"

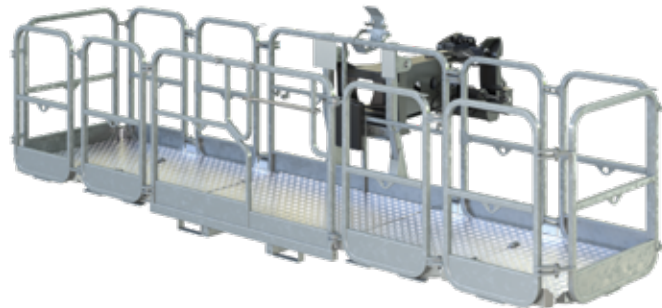





ATT - 01 - 009

Extendable rotating platform with a maximum load capacity of 1,100 lb, type-approved to carry three operators. Galvanised, reinforced steel structure. Non-slip floor for increased operator safety even in wet conditions. The platform is equipped with an overload sensor and rack with anti-shock system to ensure smooth, rotational movements when stopping and starting. An efficient patented extension system provides extra reach of 3'3" per side. The base of the platform is equipped with fork insertion points.

CHECK FOR ANY PREARRANGEMENT REQUIREMENTS

REP 2-5.5

				
1,100 lb	7'8" - 14'10" x 3'9"	+ / - 90°	3	✓

EXTENDABLE ROTATING PLATFORM, 1,100 LB - 21' 4"







ATT - 01 - 011

Extendable rotating platform with a maximum load capacity of 1,100 lb, type-approved to carry three operators. Galvanised, reinforced steel structure. Non-slip floor for increased operator safety even in wet conditions. The platform is equipped with an overload sensor and rack with anti-shock system to ensure smooth, rotational movements when stopping and starting. An efficient patented extension system provides extra reach of 3'3" per side. The base of the platform is equipped with fork insertion points.

CHECK FOR ANY PREARRANGEMENT REQUIREMENTS

REP 2-6.5

				
1,100 lb	7'8" - 21'5" x 3'9"	+ / - 90°	3	✓

EXTENDABLE ROTATING PLATFORM, 2,200 LB







ATT - 01 - 016

Extendable rotating platform with a maximum load capacity of 2,200 lb, type-approved to carry three operators. Galvanised, reinforced steel structure. Non-slip floor for increased operator safety even in wet conditions. The platform is equipped with an overload sensor and rack with anti-shock system to ensure smooth, rotational movements when stopping and starting. An efficient patented extension system provides extra reach of 3'3" per side. The base of the platform is equipped with fork insertion points.

CHECK FOR ANY PREARRANGEMENT REQUIREMENTS

REP 10.2-4,7

				
2,200 lb	7'9.8" -15'4.4" x 3'9"	+ / - 90°	3	✓



TELESCOPIC PLATFORM, 440 LB

ATT - 01 - 022

Telescopic platform with a maximum load capacity of 440 lb, type-approved to carry two operators. Its telescopic boom extends the machine's maximum height with a standard platform by up to 33' 5". Galvanised, reinforced steel structure. Non-slip floor for increased operator safety even in wet conditions. Rotation (+/- 90°) provided by a hydraulic rotating actuator.

CHECK FOR ANY PREARRANGEMENT REQUIREMENTS

TP 2.10

440 lb	4'7" x 2'2"	+ / - 90°	2	21'1" - 33'5"	21'1.5" - 32'0.6"	10' 11"	✓



TELESCOPIC PLATFORM, POSITIVE/NEGATIVE, 550 LB

ATT - 01 - 024

Telescopic platform with a maximum load capacity of 550 lb, type-approved to carry two operators. Enables work in positive and negative positions. This makes it ideal for maintaining viaducts and all applications requiring access to hard-to-reach positions. The working mode can be changed from positive to negative hydraulically, thus ensuring operator safety. Galvanised, reinforced steel structure. Non-slip floor for increased operator safety even in wet conditions.

CHECK FOR ANY PREARRANGEMENT REQUIREMENTS

TP O-U-R

550 lb	4'1" x 2'10"	340° hydraulic	2	13'6.7" - 20'7"	9'5" - 15'1"	12'11" - 18'8"	5'11"	✓









TELESCOPIC PLATFORM, 1,000 LB

ATT - 01 - 004

Telescopic extensible platform with maximum capacity of 1,000 lb and approved for three people. Thanks to the telescopic boom with which it is equipped, it allows for a maximum working height of 39' 4" more than a standard platform. Galvanised and reinforced steel structure. Non-slip floor design to ensure greater operator stability even in wet conditions. The 360° rotation with closed boom combined with the +/-20° angular correction with the boom extended, makes this platform a cutting-edge solution for working at height.

TP 4.5.10

							
1,000 lb	8' x 3'	360°	3	21'9" - 32'11"	22'7" - 37'10"	9'8"	✓







MINING PLATFORM, 1,000 LB

ATT - 01 - 027

A special platform for use in mines, with a maximum load capacity of 1,000 lb, type-approved to carry two operators. It is equipped with an integral protection grille over the platform to protect against falling debris. The grille is equipped with anti-crushing sensors for increased protection against human error. Galvanised, reinforced steel structure. Non-slip floor for increased operator safety even in wet conditions. The base of the platform is equipped with fork insertion points.

**CHECK FOR ANY PREARRANGEMENT
REQUIREMENTS**

CP 1.8

			
1,000 lb	5'11" x 3'3"	2	✓



EXTENDABLE ROTATING PLATFORM, 1,100 LB, WITH 1,300 LB CAPACITY WINCH

ATT - 01 - 026

Extendable rotating platform with a maximum load capacity of 1,100 lb, type-approved to carry three operators. Equipped with a 1,300 lb capacity hydraulic winch, +/- 90° rotation, 0-64° lifting and 161' cable. Galvanised, reinforced steel structure. Non-slip floor for increased operator safety even in wet conditions. The platform is equipped with an overload sensor and rack with anti-shock system to ensure smooth, rotational movements when stopping and starting. An efficient patented extension system provides extra reach of 3'3" per side. The base of the platform is equipped with fork insertion points.

CHECK FOR ANY PREARRANGEMENT REQUIREMENTS

REP 5.2-4,5 WO,6

1,100 lb	7'8" - 14'10" x 3'7"	+ / - 90°	3	1,300 lb	6'8"	+ / - 90° manual	0° /64°	161'		

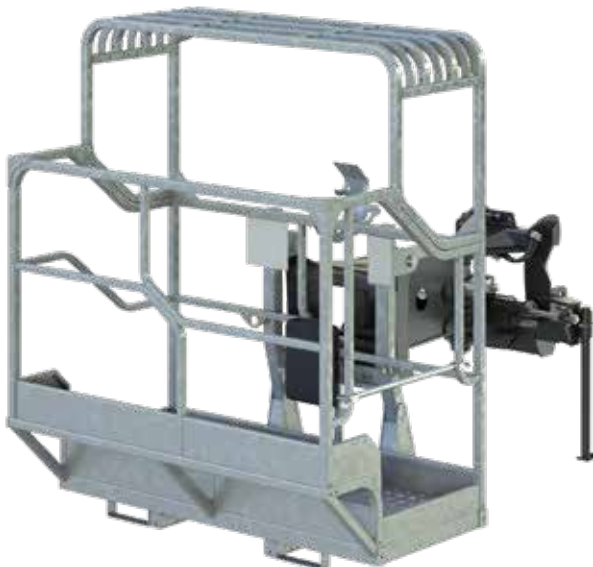

ROTATING PLATFORM FOR WORKING IN TUNNELS 1,100 LB

ATT - 01 - 013

Special platform for use in mines or tunnels, with a maximum load capacity of 1,100 lb, type-approved to carry three operators. It is equipped with an integral protection grille over the platform to protect against crushing and falling debris. Galvanised, reinforced steel structure. Non-slip floor for increased operator safety even in wet conditions. The platform is equipped with an anti-shock system to ensure smooth, rotational movements when stopping and starting. The base of the platform is equipped with fork insertion points.

CHECK FOR ANY PREARRANGEMENT REQUIREMENTS

CRP 5

1,100 lb	5'11" x 3'3"	+/- 90°, hydraulic	3	

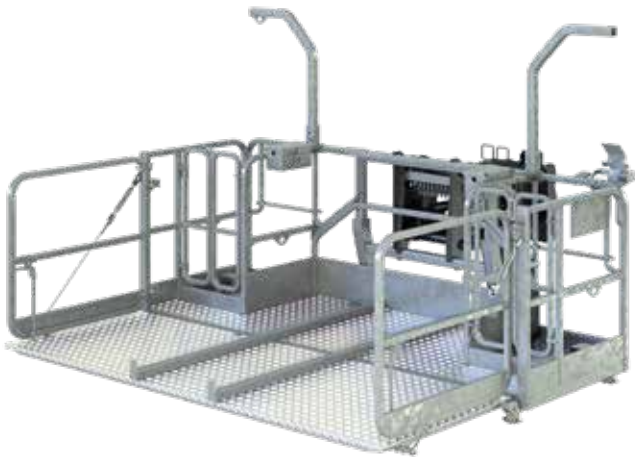





EXTENDABLE ROTATING PLATFORM, 2,200 LB, FOR ASBESTOS MITIGATION

ATT - 01 - 018

Special platform for asbestos removal from elevated positions with a load capacity of 2,200 lb, type-approved to carry two operators. It features two closed stations to accommodate the operators with enabling pedal switches. Both operators must depress their pedal before the platform will move. This makes it possible to move and transfer materials on the roof with the front bulkhead folded down. Non-slip floor for increased operator safety even in wet conditions. The platform is equipped with an overload sensor and rack with anti-shock system to ensure smooth, rotational movements when stopping and starting.

CHECK FOR ANY PREARRANGEMENT REQUIREMENTS

RPRAB 10-3,5

				
2,200 lb	Open: 11'6" x 7'3" Closed: 11'6" x 3'9"	+/- 90°, hydraulic	2	✓

EXTENDABLE ROTATING PLATFORM FOR ROOFING APPLICATIONS, 2,200 LB









ATT - 01 - 020

Extendable rotating platform with a maximum load capacity of 2,200 lb, type-approved to carry three operators. It features an openable bulkhead to facilitate loading and unloading materials. The platform has sensors which disable its movement when the basket is open. Galvanised, reinforced steel structure. Non-slip floor for increased operator safety even in wet conditions. The platform is equipped with an overload sensor and rack with anti-shock system to ensure smooth, rotational movements when stopping and starting. The base of the platform is equipped with fork insertion points.

CHECK FOR ANY PREARRANGEMENT REQUIREMENTS

RRP 10.2,5-3,5

						
2,200 lb	Open: 11'3" x 6'2" Closed: 8'1" x 6'2"	+/- 90°, hydraulic	3	6'7"	2'5"	✓

COMPATIBILITY

	ATT-01-001	ATT-01-002	ATT-01-003	ATT-01-004	ATT-01-005	ATT-01-007	ATT-01-009	ATT-01-011
RTH 5.18	✓	✗	✓	✗	✓	✓	✓	✓
RTH 5.21	✓	✗	✓	✗	✓	✓	✓	✓
RTH 5.23	✓	✗	✓	✗	✓	✓	✓	✓
RTH 5.25	✓	✗	✓	✗	✓	✓	✓	✓
RTH 6.22	✓	✗	✓	✗	✓	✓	✓	✓
RTH 6.22 EC/TC	✓	✗	✓	✗	✓	✓	✓	✓
RTH 6.26	✓	✗	✓	✗	✓	✓	✓	✓
RTH 6.26 EC/TC	✓	✗	✓	✗	✓	✓	✓	✓
RTH 6.31	✓	✗	✓	✗	✓	✓	✓	✓
RTH 6.31 EC/TC	✓	✗	✓	✗	✓	✓	✓	✓
RTH 6.51	✓	✗	✓	✗	✓	✓	✓	✓
RTH 8.27	✓	✗	✓	✓	✓	✓	✓	✓
RTH 8.35	✓	✗	✓	✓	✓	✓	✓	✓
RTH 8.39	✓	✗	✓	✗	✓	✓	✓	✓
RTH 8.46	✓	✗	✓	✓	✓	✓	✓	✓
RTH 10.37	✓	✗	✓	✗	✓	✓	✓	✓
RTH 13.26	✓	✗	✓	✗	✓	✓	✓	✓
TH 3.6	✗	✓	✗	✗	✗	✗	✗	✗
TH 4,5.15	✓	✗	✓	✗	✗	✓	✗	✗
TH 4,5.19	✓	✗	✓	✗	✗	✓	✗	✗
TH 5.8	✓	✗	✓	✗	✗	✗	✗	✗
TH 5,5.15	✓	✗	✓	✗	✗	✓	✗	✗
TH 5,5.19	✓	✗	✓	✗	✗	✓	✗	✗
TH 5,5.24	✓	✗	✓	✗	✗	✓	✗	✗
TH 6.20	✓	✗	✓	✗	✗	✓	✗	✗
TH 7.10	✓	✗	✓	✗	✗	✗	✗	✗
HTH 10.10	✗	✗	✗	✗	✗	✓	✗	✗
HTH 12.10	✗	✗	✗	✗	✗	✓	✗	✗
HTH 16.10	✗	✗	✗	✗	✗	✗	✗	✗
HTH 20.10	✗	✗	✗	✗	✗	✗	✗	✗
HTH 25.11	✗	✗	✗	✗	✗	✗	✗	✗
HTH 27.11	✗	✗	✗	✗	✗	✗	✗	✗
HTH 30.12	✗	✗	✗	✗	✗	✗	✗	✗
HTH 35.12	✗	✗	✗	✗	✗	✗	✗	✗
HTH 50.14	✗	✗	✗	✗	✗	✗	✗	✗

	ATT-01-013	ATT-01-016	ATT-01-018	ATT-01-020	ATT-01-022	ATT-01-024	ATT-01-026	ATT-01-027
RTH 5.18	✓	✓	✓	✓	✓	✓	✓	✓
RTH 5.21	✓	✓	✓	✓	✓	✓	✓	✓
RTH 5.23	✓	✓	✓	✓	✓	✓	✓	✓
RTH 5.25	✓	✓	✓	✓	✓	✓	✓	✓
RTH 6.22	✓	✓	✓	✓	✓	✓	✓	✓
RTH 6.22 EC/TC	✓	✓	✓	✓	✓	✓	✓	✓
RTH 6.26	✓	✓	✓	✓	✓	✓	✓	✓
RTH 6.26 EC/TC	✓	✓	✓	✓	✓	✓	✓	✓
RTH 6.31	✓	✓	✓	✓	✓	✓	✓	✓
RTH 6.31 EC/TC	✓	✓	✓	✓	✓	✓	✓	✓
RTH 6.51	✓	✓	✓	✓	✓	✓	✓	✓
RTH 8.27	✓	✓	✓	✓	✓	✓	✓	✓
RTH 8.35	✓	✓	✓	✓	✓	✓	✓	✓
RTH 8.39	✓	✓	✓	✓	✓	✓	✓	✓
RTH 8.46	✓	✓	✓	✓	✓	✓	✓	✓
RTH 10.37	✓	✓	✓	✓	✓	✓	✓	✓
RTH 13.26	✓	✓	✓	✓	✓	✓	✓	✓
TH 3.6	✗	✗	✗	✗	✗	✗	✗	✗
TH 4,5.15	✗	✓	✗	✗	✗	✗	✗	✓
TH 4,5.19	✗	✓	✗	✗	✗	✗	✗	✓
TH 5.8	✗	✗	✗	✗	✗	✗	✗	✓
TH 5,5.15	✗	✓	✗	✗	✗	✗	✗	✓
TH 5,5.19	✗	✓	✗	✗	✗	✗	✗	✓
TH 5,5.24	✗	✓	✗	✗	✗	✗	✗	✓
TH 6.20	✗	✓	✗	✗	✗	✗	✗	✓
TH 7.10	✗	✗	✗	✗	✗	✗	✗	✓
HTH 10.10	✗	✓	✗	✗	✗	✗	✗	✓
HTH 12.10	✗	✓	✗	✗	✗	✗	✗	✓
HTH 16.10	✗	✗	✗	✗	✗	✗	✗	✗
HTH 20.10	✗	✗	✗	✗	✗	✗	✗	✗
HTH 25.11	✗	✗	✗	✗	✗	✗	✗	✗
HTH 27.11	✗	✗	✗	✗	✗	✗	✗	✗
HTH 30.12	✗	✗	✗	✗	✗	✗	✗	✗
HTH 35.12	✗	✗	✗	✗	✗	✗	✗	✗
HTH 50.14	✗	✗	✗	✗	✗	✗	✗	✗

✓: yes ✗: no

WINCHES



Our winches offer unbeatable performance for effortlessly lifting and moving loads. Compact and robust, these first-class attachments offer Magni's hallmark quality in every detail.

Check the compatibility and capacity of each attachment with your dealer.







DOUBLE PULL WINCH 6,000 LB

ATT - 02 - 001

Winch with a maximum load capacity of 6,000 lb, equipped with a type-approved swivel hook with safety catch. The attachment is equipped with a rope pressure roller and hydraulic limit switch system for rope raising/lowering. Metal storage support included.

W 2,7

				
6,000 lb	0.4"	82'	79 ft/min	✓







DOUBLE PULL WINCH 7,700 LB

ATT - 02 - 002

Winch with a maximum load capacity of 7,700 lb, equipped with a type-approved swivel hook. The attachment is equipped with a rope pressure roller and hydraulic limit switch system for rope raising/lowering. Metal storage support included.

W 3,5

				
7,700 lb	0.4"	82'	82 ft/min	✓







SINGLE PULL WINCH 3,850 LB / DOUBLE PULL WINCH 7,700 LB

ATT - 02 - 009

Winch configurable for two load capacities: 7,700 lb double pull and 3,850 lb single pull. The attachment is equipped with a rope pressure roller and hydraulic limit switch system for rope raising/lowering. Metal storage support included.

W 3,5 - 1,75

				
3,850 / 7,700 lb	0.4"	177' / 89'	157 / 79 ft/min	✓







DOUBLE PULL WINCH 11,000 LB

ATT - 02 - 019

Winch with a maximum load capacity of 11,000 lb, equipped with a type-approved swivel hook. The attachment is equipped with a rope pressure roller and hydraulic limit switch system for rope raising/lowering. Metal storage support included.

W 5

				
11,000 lb	0.5"	190'	62 ft/min	✓







DOUBLE PULL WINCH 13,200 LB

ATT - 02 - 004

Winch with a maximum load capacity of 13,200 lb, equipped with a type-approved swivel hook. The attachment is equipped with a rope pressure roller and hydraulic limit switch system for rope raising/lowering. Metal storage support included.

W 6

				
13,200 lb	0.5"	190'	62 ft/min	✓







SINGLE PULL WINCH 6,600 LB / DOUBLE PULL WINCH 13,200 LB

ATT - 02 - 010

Winch configurable for two load capacities: 13,200 lb double pull and 6,600 lb single pull. The attachment is equipped with a rope pressure roller and hydraulic limit switch system for rope raising/lowering. Metal storage support included.

W 3 - 6

				
6,600 / 13,200 lb	0.5"	190' (single pull 6,600 lb) 85' (double pull 13,200 lb)	105 / 52 ft/min	✓







DOUBLE PULL WINCH 17,600 LB

ATT - 02 - 006

Winch with a maximum load capacity of 17,600 lb, equipped with a type-approved swivel hook. The attachment is equipped with a rope pressure roller and hydraulic limit switch system for rope raising/lowering. Metal storage support included.

W 8

				
17,600 lb	0.6"	289'	43 ft/min	✓







SINGLE PULL WINCH 8,800 LB / DOUBLE PULL WINCH 17,600 LB

ATT - 02 - 023

Winch configurable for two load capacities: 17,600 lb double pull and 8,800 lb single pull. The attachment is equipped with a rope pressure roller and hydraulic limit switch system for rope raising/lowering. Metal storage support included.

W 4 - 8

				
17,600 / 8,800 lb	0.6"	272' (single pull 8,800 lb) 135' (double pull 17,600 lb)	43 ft/min	✓



WINCH SINGLE PULL 11,000 LB / DOUBLE PULL 22,000 LB

ATT - 02 - 021

Winch configurable for two load capacities: 22,000 lb double pull and 11,000 lb single pull. The attachment is equipped with a rope pressure roller and hydraulic limit switch system for rope raising/lowering. Metal storage support included.

W 5 - 10

22,000 / 11,000 lb	0.6"	272' (single pull 11,000 lb) 135' (double pull 22,000 lb)	43 ft/min	✓



DOUBLE PULL WINCH 35,300 LB

ATT - 02 - 008

Winch with a maximum load capacity of 35,300 lb, equipped with a type-approved swivel hook. The attachment is equipped with a rope pressure roller and hydraulic limit switch system for rope raising/lowering. Metal support for handling included.

W 16

35,300 lb	0.6"	289'	33 ft/min	✓







DOUBLE PULL WINCH 28,600 LB

ATT - 02 - 018

Winch with a maximum load capacity of 28,600 lb, equipped with a type-approved swivel hook. The attachment is equipped with a rope pressure roller and hydraulic limit switch system for rope raising/lowering. Metal storage support included.

W 13

				
28,600 lb	0.6"	289'	26 ft/min	✓





WINCH BOOM, SINGLE PULL 6,600 LB / DOUBLE PULL 13,200 LB - FOR RTH 6.22, FOR ROAD USE

ATT - 02 - 022

Winch configurable for two load capacities: 13,200 lb double pull and 6,600 lb single pull, equipped with a type-approved swivel hook. The attachment is equipped with a rope pressure roller and hydraulic limit switch system for rope raising/lowering. Improved performance compared to the W6 due to its configuration with the drum mounted on the boom and not directly fastened to the winch.

WB 6

				
13,200 / 6,600 lb	0.5"	312' (single pull 6,600 lb) 156' (double pull 13,200 lb)	52 ft/min	✓







REAR BOOM WINCH, SINGLE PULL 6,600 LB / DOUBLE PULL 13,200 LB - FOR RTH 6.26, FOR ROAD USE

ATT - 02 - 012

Winch configurable for two load capacities: 13,200 lb double pull and 6,600 lb single pull, equipped with a type-approved swivel hook. The attachment is equipped with a rope pressure roller and hydraulic limit switch system for rope raising/lowering. Improved performance compared to the W6 due to its configuration with the drum mounted on the boom and not directly fastened to the winch.

WB 6

				
13,200 / 6,600 lb	0.5"	312' (single pull 6,600 lb) 156' (double pull 13,200 lb)	52 ft/min	









REAR BOOM WINCH, SINGLE PULL 6,600 LB / DOUBLE PULL 13,200 LB - FOR RTH 6.31, FOR ROAD USE

ATT - 02 - 013

Winch configurable for two load capacities: 13,200 lb double pull and 6,600 lb single pull, equipped with a type-approved swivel hook. The attachment is equipped with a rope pressure roller and hydraulic limit switch system for rope raising/lowering. Improved performance compared to the W6 due to its configuration with the drum mounted on the boom and not directly fastened to the winch.

WB 6

				
13,200 / 6,600 lb	0.5"	312' (single pull 6,600 lb) 156' (double pull 13,200 lb)	105 ft/min (single pull) 56 ft/min (double pull)	









REAR BOOM WINCH, SINGLE PULL 8,800 LB / DOUBLE PULL 17,600 LB - FOR RTH 8.27, FOR ROAD USE

ATT - 02 - 005

Winch configurable for two load capacities: 17,600 lb double pull and 8,800 lb single pull, equipped with a type-approved swivel hook. The attachment is equipped with a rope pressure roller and hydraulic limit switch system for rope raising/lowering. Improved performance compared to the W6 due to its configuration with the drum mounted on the boom and not directly fastened to the winch.

WB 8

				
17,600 / 8,800 lb	0.6"	289' (single pull 8,800 lb) 144' (double pull 17,600 lb)	144 ft/min	

COMPATIBILITY

	ATT-02-001	ATT-02-002	ATT-02-004	ATT-02-005	ATT-02-006	ATT-02-008	ATT-02-009	ATT-02-010
RTH 5.18	✓	✓	✓	✗	✓	✗	✓	✓
RTH 5.21	✓	✓	✓	✗	✓	✗	✓	✓
RTH 5.23	✓	✓	✓	✗	✓	✗	✓	✓
RTH 5.25	✓	✓	✓	✗	✓	✗	✓	✓
RTH 6.22	✓	✓	✓	✗	✓	✗	✓	✓
RTH 6.22 EC/TC	✓	✓	✓	✗	✓	✗	✓	✓
RTH 6.26	✓	✓	✓	✗	✓	✗	✓	✓
RTH 6.26 EC/TC	✓	✓	✓	✗	✓	✗	✓	✓
RTH 6.31	✓	✓	✓	✗	✓	✗	✓	✓
RTH 6.31 EC/TC	✓	✓	✓	✗	✓	✗	✓	✓
RTH 6.51	✓	✓	✓	✗	✓	✗	✓	✓
RTH 8.27	✓	✓	✓	✓	✓	✗	✓	✓
RTH 8.35	✓	✓	✓	✗	✓	✗	✓	✓
RTH 8.39	✓	✓	✓	✗	✓	✗	✓	✓
RTH 8.46	✓	✓	✓	✗	✓	✗	✓	✓
RTH 10.37	✓	✓	✓	✗	✓	✗	✓	✓
RTH 13.26	✓	✓	✓	✗	✓	✗	✓	✓
TH 3.6	✗	✗	✗	✗	✗	✗	✗	✗
TH 4,5.15	✓	✓	✓	✗	✗	✗	✓	✓
TH 4,5.19	✓	✓	✓	✗	✗	✗	✓	✓
TH 5.8	✓	✓	✓	✗	✗	✗	✓	✓
TH 5,5.15	✓	✓	✓	✗	✗	✗	✓	✓
TH 5,5.19	✓	✓	✓	✗	✗	✗	✓	✓
TH 5,5.24	✓	✓	✓	✗	✗	✗	✓	✓
TH 6.20	✓	✓	✓	✗	✗	✗	✓	✓
TH 7.10	✓	✓	✓	✗	✗	✗	✓	✓
HTH 10.10	✗	✗	✓	✗	✗	✗	✗	✗
HTH 12.10	✗	✗	✓	✗	✗	✗	✗	✗
HTH 16.10	✗	✗	✗	✗	✗	✓	✗	✗
HTH 20.10	✗	✗	✗	✗	✗	✓	✗	✗
HTH 25.11	✗	✗	✗	✗	✗	✓	✗	✗
HTH 27.11	✗	✗	✗	✗	✗	✓	✗	✗
HTH 30.12	✗	✗	✗	✗	✗	✓	✗	✗
HTH 35.12	✗	✗	✗	✗	✗	✓	✗	✗
HTH 50.14	✗	✗	✗	✗	✗	✗	✗	✗

	ATT-02-012	ATT-02-013	ATT-02-018	ATT-02-019	ATT-02-021	ATT-02-022	ATT-02-023
RTH 5.18	X	X	✓	✓	✓	X	✓
RTH 5.21	X	X	✓	✓	✓	X	✓
RTH 5.23	X	X	✓	✓	✓	X	✓
RTH 5.25	X	X	✓	✓	✓	X	✓
RTH 6.22	X	X	✓	✓	✓	✓	✓
RTH 6.22 EC/TC	X	X	✓	✓	✓	✓	✓
RTH 6.26	✓	X	✓	✓	✓	X	✓
RTH 6.26 EC/TC	✓	X	✓	✓	✓	X	✓
RTH 6.31	X	✓	✓	✓	✓	X	✓
RTH 6.31 EC/TC	X	✓	✓	✓	✓	X	✓
RTH 6.51	X	X	✓	✓	✓	X	✓
RTH 8.27	X	X	✓	✓	✓	X	✓
RTH 8.35	X	X	✓	✓	✓	X	✓
RTH 8.39	X	X	✓	✓	✓	X	✓
RTH 8.46	X	X	✓	✓	✓	X	✓
RTH 10.37	X	X	✓	✓	✓	X	✓
RTH 13.26	X	X	✓	✓	✓	X	✓
TH 3.6	X	X	X	X	X	X	X
TH 4,5.15	X	X	X	✓	X	X	X
TH 4,5.19	X	X	X	✓	X	X	X
TH 5.8	X	X	X	✓	X	X	X
TH 5,5.15	X	X	X	✓	X	X	X
TH 5,5.19	X	X	X	✓	X	X	X
TH 5,5.24	X	X	X	✓	X	X	X
TH 6.20	X	X	X	✓	X	X	X
TH 7.10	X	X	X	✓	X	X	X
HTH 10.10	X	X	X	X	X	X	X
HTH 12.10	X	X	X	X	X	X	X
HTH 16.10	X	X	X	X	X	X	X
HTH 20.10	X	X	X	X	X	X	X
HTH 25.11	X	X	X	X	X	X	X
HTH 27.11	X	X	X	X	X	X	X
HTH 30.12	X	X	X	X	X	X	X
HTH 35.12	X	X	X	X	X	X	X
HTH 50.14	X	X	X	X	X	X	X

✓: yes X: no

FORK CARRIAGES



Ideally suited to even the most demanding applications, like quarries and mines, our fork carriages can handle any job even under extreme conditions. From simple fork carriages to heavy-duty units with oversized forks, we have the best solution to get the job done.

Check the compatibility and capacity of each attachment with your dealer.

FLOATING FORK CARRIAGE 3 T



ATT - 03 - 016

Fork carriage with a load capacity of 6,600 lb. The 3'11" floating forks enable the load to be picked up even from uneven surfaces. The forks can be locked in the transport position for greater safety on the road.

FCFS 3T FIX

<p>6,600 lb</p>	<p>3'11"</p>	<p>0.7' (min.) - 3'5" (max.)</p>	<p>✓</p>

FEM FORK CARRIAGE 6,600 LB

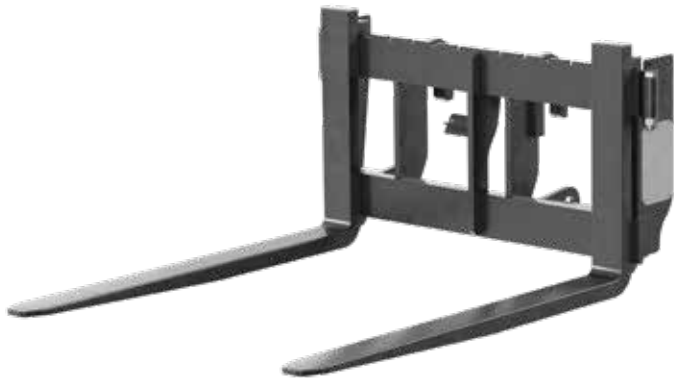

ATT - 03 - 034

FEM fork carriage with a load capacity of 6,600 lb and width of 3'7". The 3'11" long, laterally sliding forks are ideal for handling all types of palletised loads and any other application requiring non-floating forks.

FCFS 3T FIX

<p>5,500 lb</p>	<p>3'11"</p>	<p>0.8' (min.) - 3'5" (max.)</p>	<p>✓</p>





FLOATING FORK CARRIAGE 10,000 LB

ATT - 03 - 042

Fork carriage with a load capacity of 10,000 lb. The 3'11" floating forks enable the load to be picked up even from uneven surfaces. The forks can be locked in the transport position for greater safety on the road.



FC 4,5T FIX

 10,000 lb	 3'11"	 1'11" (min.) - 3'5" (max.)	 
--	--	--	---





FLOATING FORK CARRIAGE 11,000 LB

ATT - 03 - 039

Fork carriage with a load capacity of 11,000 lb. The 3'11" floating forks enable the load to be picked up even from uneven surfaces. The forks can be locked in the transport position for greater safety on the road.



FC 5T FIX

 11,000 lb	 3'11"	 0.7' (min.) - 3' 5" (max.)	 
--	--	--	--







FLOATING FORK CARRIAGE 12,100 LB

ATT - 03 - 040

Fork carriage with a load capacity of 12,100 lb. The 3'11" floating forks enable the load to be picked up even from uneven surfaces. The forks can be locked in the transport position for greater safety on the road.

FC 5,5T FIX

			
12,100 lb	3'11"	0.7' (min.) - 3'5" (max.)	✓







FLOATING FORK CARRIAGE 13,200 LB

ATT - 03 - 004

Fork carriage with a load capacity of 13,200 lb. The 3'11" floating forks enable the load to be picked up even from uneven surfaces. The forks can be locked in the transport position for greater safety on the road.

FC 6T FIX L S

			
13,200 lb	3'11"	1'11" (min.) - 3'5" (max.)	✓

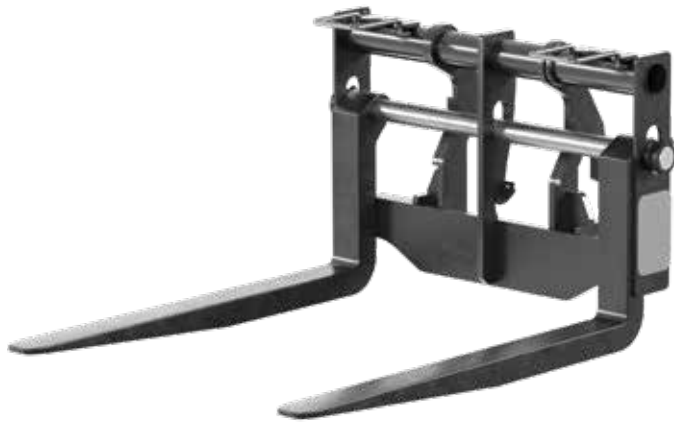





FLOATING FORK CARRIAGE 15,400 LB

ATT - 03 - 011

Fork carriage with a load capacity of 15,400 lb. The 3' 11" floating forks enable the load to be picked up even from uneven surfaces. The forks can be locked in the transport position for greater safety on the road.

FC 7T FIX S

 15,400 lb	 3'11"	 1'11" (min.) - 3'5" (max.)	
--	--	--	--



FEM FORK CARRIAGE FOR TH

ATT - 03 - 043

FEM fork carriage with a load capacity of 13,200 lb and width of 4'3". The 3'11" long, laterally sliding forks are ideal for handling all types of palletised loads and any other application requiring non-floating forks.

FCF 1,3 FIX

 13,200 lb <small>* The actual capacity will depend on the machine to which the attachment is mounted (4.5 t; 5 t; 5.5 t)</small>	 3'11"	 0.9' (min.) - 4'4" (max.)	
--	--	---	---



FORK CARRIAGE WITH POSITIONER

ATT - 03 - 045

Fork carriage for the TH range (excluding TH 3.6), width of 3'4". The 3'11" long forks are ideal for handling all types of palletised loads and any other application requiring non-floating forks. Equipped with a positioner that moves the individual forks hydraulically.

FCP FIX

 <p>13,200 lb <i>* The actual capacity will depend on the machine to which the attachment is mounted (4.5 t; 5 t; 5.5 t)</i></p>	 <p>3'11"</p>	 <p>0.8' (min.) - 3'4" (max.)</p>	
---	--	--	--







FEM FORK CARRIAGE WITH SIDE SHIFT

ATT - 03 - 044

FEM fork carriage with a load capacity of 11,000 lb and width of 4'3". The 3'11" long laterally sliding forks are controlled directly from the cab with a hydraulic side shift, and are ideal for handling all types of palletised loads and any other application requiring non-floating forks.

FCTF

 <p>11,000 lb <i>* The actual capacity will depend on the machine to which the attachment is mounted (4.5 t; 5 t; 5.5 t)</i></p>	 <p>3'11"</p>	 <p>0.9' (min.) - 3'11" (max.)</p>	 <p>4"</p>	
---	--	---	---	---







FEM FORK CARRIAGE WITH POSITIONER AND SIDE SHIFT

ATT - 03 - 046

Fork carriage for the TH range (excluding TH 3.6) with a width of 3'7". 3'11" long forks are ideal for handling all types of palletised loads and any other application requiring non-floating forks. Equipped with a positioner to hydraulically move the individual forks and a hydraulic side shift to slide them laterally, directly from the cab.

FCPT FIX R

 <p>13,200 lb * The actual capacity will depend on the machine to which the attachment is mounted (4.5 t; 5 t; 5.5 t)</p>	 <p>3'11"</p>	 <p>1'10" (min.) - 3'7" (max.)</p>	
--	--	--	--





WIDE FORK CARRIAGE WITH LONG FORKS (72X72")

ATT - 03 - 048

Fork carriage for the TH range (excluding TH 3.6) with a width of 6'0.4". Floating forks with an extended length of 6' allow bulky loads to be picked up even from uneven surfaces. The forks can be locked in the transport position for greater safety on the road.



FC 72x72 FIX

 <p>10,000 lb * The actual capacity will depend on the machine to which the attachment is mounted (4.5 t; 5 t; 5.5 t)</p>	 <p>6'</p>	 <p>1'11" (min.) - 6'0.4" (max.)</p>	
--	---	--	---





WIDE FORK CARRIAGE WITH LONG FORKS (72X60")



ATT - 03 - 049

Fork carriage for the TH range (excluding TH 3.6) with a width of 6'0.4". Floating forks with an extended length of 4'11" allow bulky loads to be picked up even from uneven surfaces. The forks can be locked in the transport position for greater safety on the road.

FC 6x5 FIX

 10,000 lb <small>* The actual capacity will depend on the machine to which the attachment is mounted (4.5 t; 5 t; 5.5 t)</small>	 4'11"	 1'11" (min.) - 6'0.4" (max.)	
--	--	--	--





FLOATING FORK CARRIAGE 11,000 LB



ATT - 03 - 001

Fork carriage with a load capacity of 11,000 lb. The 3'11" floating forks enable the load to be picked up even from uneven surfaces. The forks can be locked in the transport position for greater safety on the road.

FC 5T

 11,000 lb	 3'11"	 1'8" (min.) - 3'5" (max.)	
--	--	---	---

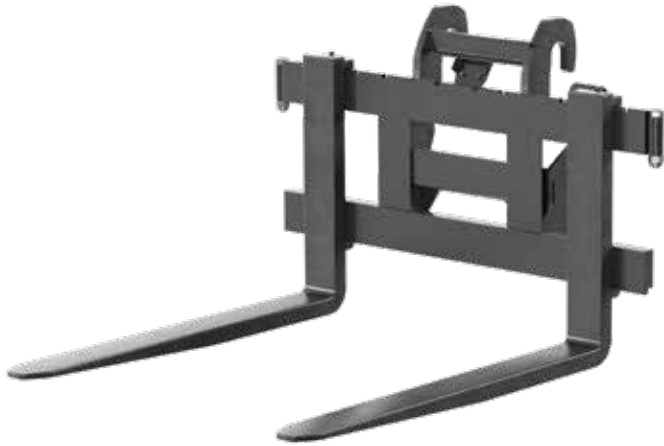





FEM STANDARD FORK CARRIAGE, 11,000 LB

ATT - 03 - 003

FEM fork carriage with a load capacity of 11,000 lb and width of 4'3". The 3'11" long, laterally sliding forks are ideal for handling all types of palletised loads and any other application requiring non-floating forks.

FCF 5T 1,3

 11,000 lb	 3'11"	 0.8' (min.) - 4'3" (max.)	 
--	--	---	---







FLOATING FORK CARRIAGE 13,200 LB

ATT - 03 - 006

Fork carriage with a load capacity of 13,200 lb. The 3'11" floating forks enable the load to be picked up even from uneven surfaces. The forks can be locked in the transport position for greater safety on the road.

FC 6T L

 13,200 lb	 3'11"	 1'1" (min.) - 3'5" (max.)	 
--	--	---	--







FLOATING FORK CARRIAGE 13,200 LB

ATT - 03 - 008

Fork carriage with a load capacity of 13,200 lb. The 3'11" floating forks enable the load to be picked up even from uneven surfaces. The forks can be locked in the transport position for greater safety on the road.

FC 6T

			
13,200 lb	3'11"	1'11" (min.) - 3'5" (max.)	✓

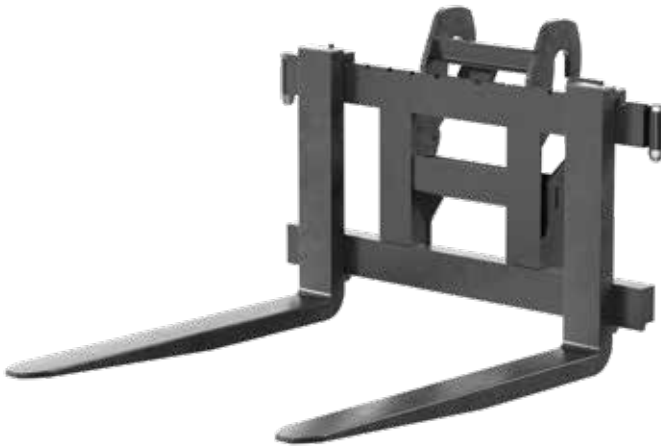





FEM FORK CARRIAGE 13,200 LB

ATT - 03 - 010

FEM fork carriage with a load capacity of 13,200 lb and width of 4'3". The 3'11" long, laterally sliding forks are ideal for handling all types of palletised loads and any other application requiring non-floating forks.

FCF 6T 1,3

			
13,200 lb	3'11"	0.9' (min.) - 4'3" (max.)	✓



FLOATING FORK CARRIAGE 13,200 LB (WIDE) WITH 4' 11" LONG FORKS

ATT - 03 - 009

Fork carriage with a load capacity of 13,200 lb and width of 6'0.4". Floating forks with an extended length of 5'1" allow bulky loads to be picked up even from uneven surfaces. The forks can be locked in the transport position for greater safety on the road. Grille for load protection and support included.

FC 6T 6x5 FT

13,200 lb	5'1"	2'5" (min.) - 6'0.4" (max.)	



FLOATING FORK CARRIAGE 13,200 LB (WIDE) WITH 5'11" LONG FORKS

ATT - 03 - 014

Fork carriage with a load capacity of 13,200 lb and width of 6'0.4". Floating forks with an extended length of 6' allow bulky loads to be picked up even from uneven surfaces. The forks can be locked in the transport position for greater safety on the road.

FC 6T 72x72 FIX

13,200 lb	6'	2'3" (min.) - 6'0.4" (max.)	







FLOATING FORK CARRIAGE 17,600 LB

ATT - 03 - 015

Fork carriage with a load capacity of 17,600 lb. The 3'11" floating forks enable the load to be picked up even from uneven surfaces. The forks can be locked in the transport position for greater safety on the road.

FC 8T L

			
17,600 lb	3'11"	1'1" (min.) - 3'5" (max.)	✓







FLOATING FORK CARRIAGE 17,600 LB

ATT - 03 - 007

Fork carriage with a load capacity of 17,600 lb. The 3'11" floating forks enable the load to be picked up even from uneven surfaces. The forks can be locked in the transport position for greater safety on the road.

FC 8T 46 L

			
17,600 lb	3'11"	1'9" (min.) - 3'5" (max.)	✓



FLOATING FORK CARRIAGE 17,600 LB (WIDE) WITH 5'11" FORKS

ATT - 03 - 017

Fork carriage with a load capacity of 17,600 lb and width of 6'0.4". Floating forks with an extended length of 6' allow bulky loads to be picked up even from uneven surfaces. The forks can be locked in the transport position for greater safety on the road.

FC 8T 72x72

17,600 lb	6'2"	1'11" (min.) - 6'0.4" (max.)	

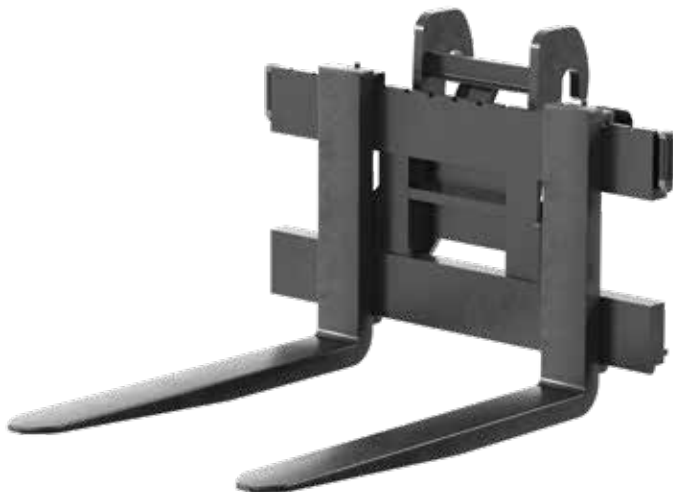

FEM FORK CARRIAGE 17,600 LB

ATT - 03 - 037

FEM fork carriage with a load capacity of 17,600 lb and width of 4'3". The 3'11" long, laterally sliding forks are ideal for handling all types of palletised loads and any other application requiring non-floating forks.

FCF 8T SH 1,3

17,600 lb	3'11"	1'0.6" (min.) - 4'4" (max.)	







FLOATING FORK CARRIAGE 22,000 LB

ATT - 03 - 047

Fork carriage with a load capacity of 22,000 lb. The 3'11" floating forks enable the load to be picked up even from uneven surfaces. The forks can be locked in the transport position for greater safety on the road.

FC 10T

 22,000 lb	 4'2"	 1'11" (min.) - 3'5" (max.)	 
--	---	--	---







FLOATING FORK CARRIAGE 28,600 LB WITH POSITIONER

ATT - 03 - 021

Fork carriage with a load capacity of 28,600 lb. The 3'11" floating forks enable the load to be picked up even from uneven surfaces. Equipped with a positioner that moves the individual forks hydraulically. Grille for load protection and support included.

FCP 13T

 28,600 lb	 4'2"	 2'9" (min.) - 5'10" (max.)	 
--	---	--	--



FEM ROTATING FORK CARRIAGE WITH TILT

ATT - 03 - 002

Rotating fork carriages with tilt function designed for handling bulky loads in tight spaces. Unlike standard forks, they can rotate and tilt, allowing the orientation of the load to be adjusted during loading and unloading. They offer a frontal load capacity of up to 11,000 lb, a rotated load capacity of up to 5,500 lb, 360° continuous rotation and a tilt of up to 70°.

RFC5

				
11,000 lb	3'11"	2'9"	360°	✓









FEM ROTATING FORK CARRIAGE

ATT - 03 - 041

Rotating FEM fork carriage designed for handling bulky materials in confined spaces. Full 360° rotation up to a height of 9'10". Above 9'10" the maximum rotation is +/- 90°, automatically limited depending on the working conditions. The forks can be fitted with a manual rotation lock that reduces the working angle to +/- 90°. This attachment offers a frontal load capacity of 11,000 lb and 5,500 lb rotated load capacity. The frontal load capacity of the attachment will depend on the model of machine to which it is mounted.

RFC5

					
11,000 lb	3'11"	3'8"	45°	360°	✓

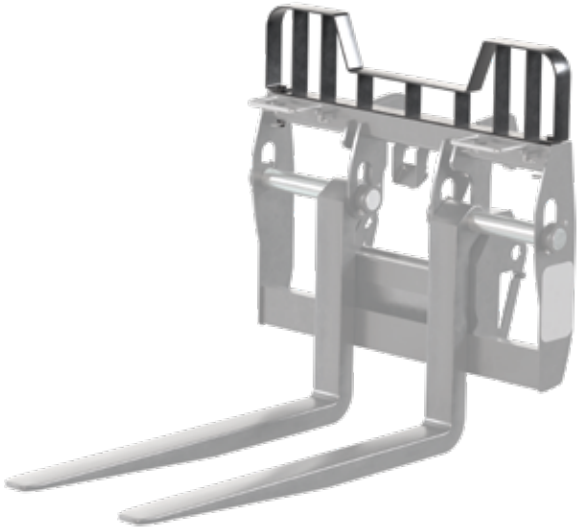

LOAD PROTECTION GRILLE FOR FLOATING FORK CARRIAGES

ATT - 03 - 038

Grille for load protection and support that can be combined with floating fork carriages to retain the load and increase operator safety.

PC



9.8" x 2.4"



LOAD PROTECTION GRILLE FOR FEM FORK CARRIAGES

ATT - 03 - 005

Grille for load protection and support that can be combined with FEM fork carriages to retain the load and increase operator safety.

PCF



3'9" x 2'0.4"



FLOATING FORK CARRIAGE 22,000 LB

ATT - 03 - 018

Fork carriage with a load capacity of 22,000 lb. The 4'11" floating forks enable the load to be picked up even from uneven surfaces. Grille for load protection and support included.

F 10T

22,000 lb	4'11"	2'8" (min.) - 5'9" (max.)	



FEM FORK CARRIAGE 5,500 LB, SIDE TIPPING - FOR EMPTYING BINS

ATT - 03 - 054

FEM fork carriage with side tipping, enables the operator to quickly unload bins by tilting the fork carriage sideways. Thanks to the continuous 360° rotation, the bins can easily be returned to the pick-up position in one smooth movement. With a load capacity of 5,500 lb, the unit is particularly suited to applications in agriculture, logistics and recycling, for optimised productivity and more efficient operation.

RFCFS 2,5 FIX

5,500 lb	3'11"	0.7' (min.) - 3'4" (max.)	360°



FLOATING FORK CARRIAGE 22,000 LB WITH POSITIONER

ATT - 03 - 019

Fork carriage with a load capacity of 22,000 lb. The 4'11" floating forks enable the load to be picked up even from uneven surfaces. Equipped with a positioner that moves the individual forks hydraulically. Grille for load protection and support included.

FCP 10T

<p>22,000 lb</p>	<p>4'11"</p>	<p>2'8" (min.) - 5'8" (max.)</p>	<p>✓</p>



FLOATING FORK CARRIAGE 22,000 LB (WIDE) WITH 8'2" LONG FORKS AND POSITIONER

ATT - 03 - 020

Fork carriage with a load capacity of 22,000 lb. The 8'2" extended length floating forks enable the load to be picked up even from uneven surfaces. Equipped with a positioner that moves the individual forks hydraulically. Grille for load protection and support included.

FCP 10T 2,5 C

<p>22,000 lb</p>	<p>8'2"</p>	<p>2'8" (min.) - 7'6" (max.)</p>	<p>✓</p>



FORK CARRIAGE 22,000 LB (WIDE) WITH POSITIONER AND SIDE SHIFT

ATT - 03 - 036

Fork carriage with a load capacity of 22,000 lb. The 4'11" extended length floating forks enable the load to be picked up even from uneven surfaces. Equipped with a positioner to hydraulically move the individual forks and a hydraulic side shift to slide them laterally, directly from the cab. Grille for load protection and support included.

FCPT 10T 1,5

22,000 lb	4'2"	1'11" (min.) - 3'5" (max.)	✓



FLOATING FORK CARRIAGE 26,890 LB

ATT - 03 - 013

Fork carriage with a load capacity of 26,890 lb. The 4'11" extended length floating forks enable the load to be picked up even from uneven surfaces. Grille for load protection and support included.

FC 12,2T

26,890 lb	4'11"	2'9" (min.) - 5'9" (max.)	✓

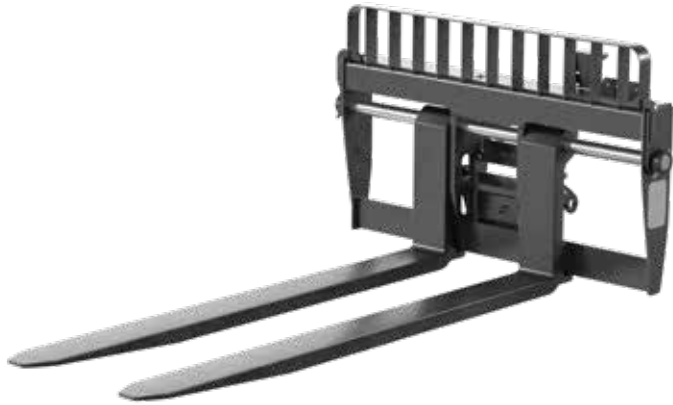

FLOATING FORK CARRIAGE 26,890 LB WITH 8'2" LONG FORKS

ATT - 03 - 050

Fork carriage with a load capacity of 26,890 lb. The 8'2" extended length floating forks enable the load to be picked up even from uneven surfaces. Grille for load protection and support included.

FC 12,2T 2,5

<p>26,890 lb</p>	<p>8'2"</p>	<p>2'9" (min.) - 5'9" (max.)</p>	<p>✓</p>



FLOATING FORK CARRIAGE 26,890 LB WITH POSITIONER

ATT - 03 - 051

Fork carriage with a load capacity of 26,890 lb. The 4'11" extended length floating forks enable the load to be picked up even from uneven surfaces. Equipped with a positioner that moves the individual forks hydraulically. Grille for load protection and support included.

FCP 12,2T

<p>26,890 lb</p>	<p>4'11"</p>	<p>2'9" (min.) - 5'9" (max.)</p>	<p>✓</p>



FLOATING FORK CARRIAGE 26,890 LB WITH 8'2" FORKS AND POSITIONER

ATT - 03 - 052

Fork carriage with a load capacity of 26,890 lb. The 8'2" floating forks enable the load to be picked up even from uneven surfaces. Equipped with a positioner that moves the individual forks hydraulically. Grille for load protection and support included.

FCP 12,2T 2,5

26,890 lb	8'2"	2'9" (min.) - 5'9" (max.)	✓

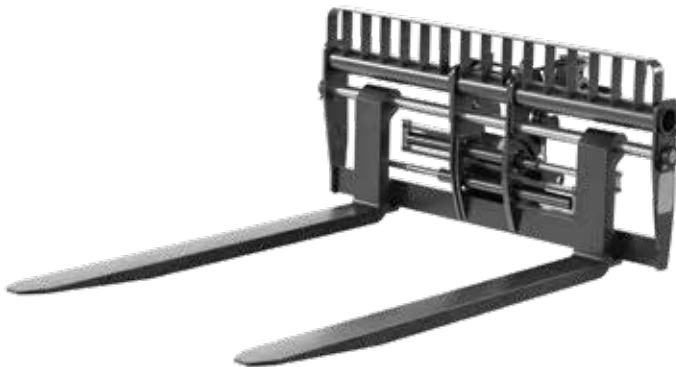

FLOATING FORK CARRIAGE 26,890 LB WITH FORKS FOR CONTAINERS AND POSITIONER

ATT - 03 - 053

Fork carriage with a load capacity of 26,890 lb. The 8'2" long, 7'6" wide forks are ideal for container handling. Equipped with a positioner that moves the individual forks hydraulically. Grille for load protection and support included.

FCP 12,2T 2,5 C

26,890 lb	8'2"	2'9" (min.) - 7'6" (max.)	✓





FLOATING FORK CARRIAGE 35,300 LB

ATT - 03 - 022

Fork carriage with a load capacity of 35,300 lb. The 4'11" floating forks enable the load to be picked up even from uneven surfaces. Grille for load protection and support included.

F 16T

			
35,300 lb	4'11"	3'8" (min.) - 6'7" (max.)	✓







FLOATING FORK CARRIAGE 35,300 LB WITH POSITIONER

ATT - 03 - 023

Fork carriage with a load capacity of 35,300 lb. The 4'11" floating forks enable the load to be picked up even from uneven surfaces. Equipped with a positioner that moves the individual forks hydraulically. Grille for load protection and support included.

FCP 16T

				
35,300 lb	4'11"	3'9" (min.) - 6'7" (max.)	+/- 1'	✓







FLOATING FORK CARRIAGE 35,300 LB WITH 7'10" LONG FORKS, WITH POSITIONER AND SIDE SHIFT

ATT - 03 - 024

Fork carriage with a load capacity of 35,300 lb. The 7'10" extended length floating forks enable the load to be picked up even from uneven surfaces. Equipped with a positioner to hydraulically move the individual forks and a hydraulic side shift to slide them laterally, directly from the cab. Grille for load protection and support included.

FCPT 16 2,4

				
35,300 lb	7'10"	1'10" (min.) - 6'6" (max.)	+/- 1'	✓







FLOATING FORK CARRIAGE 35,300 LB (WIDE) WITH 7'10" LONG FORKS AND POSITIONER

ATT - 03 - 025

Fork carriage with a load capacity of 35,300 lb. The 7'10" extended length floating forks enable the load to be picked up even from uneven surfaces. Equipped with a positioner that moves the individual forks hydraulically. Grille for load protection and support included.

FCPT 16T C

			
35,300 lb	7'10"	42" (min.) - 7'6" (max.)	✓







FLOATING FORK CARRIAGE 44,100 LB WITH POSITIONER

ATT - 03 - 026

Fork carriage with 44,100 lb load capacity. The 4'11" floating forks enable the load to be picked up even from uneven surfaces. Equipped with a positioner that moves the individual forks hydraulically. Grille for load protection and support included.

FCP 20T

 44,100 lb	 4'11"	 3'9" (min.) - 6'7" (max.)	 ✓
--	--	---	--







FLOATING FORK CARRIAGE 52,900 LB WITH POSITIONER

ATT - 03 - 027

Fork carriage with 52,900 lb load capacity. The 5'11" floating forks enable the load to be picked up even from uneven surfaces. Equipped with a positioner that moves the individual forks hydraulically. Grille for load protection and support included.

FCP 24T

 52,900 lb	 5'11"	 4'1" (min.) - 6'6" (max.)	 ✓
--	--	---	--

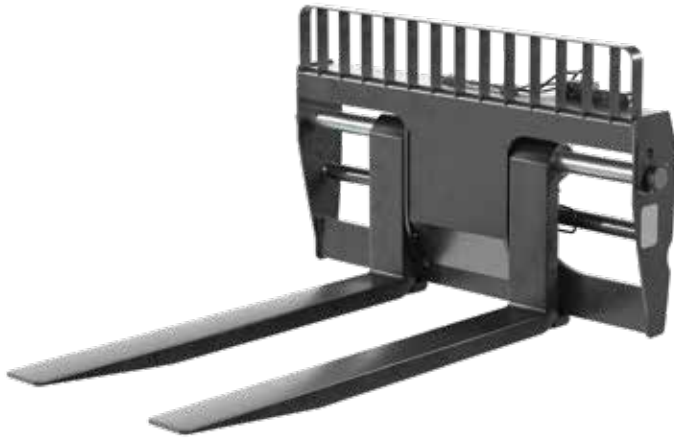

FLOATING FORK CARRIAGE 52,900 LB (WIDE) WITH 7'10" LONG FORKS AND POSITIONER

ATT - 03 - 028

Fork carriage with a load capacity of 52,900 lb. The 7'10" extended length floating forks enable the load to be picked up even from uneven surfaces. Equipped with a positioner that moves the individual forks hydraulically. Grille for load protection and support included.

FCP 24T 2,4

52,900 lb	7'10"	4'0.6" (min.) - 7'7" (max.)	



FLOATING FORK CARRIAGE 59,500 LB WITH POSITIONER

ATT - 03 - 029

Fork carriage with a load capacity of 59,500 lb. The 7'10" extended length floating forks enable the load to be picked up even from uneven surfaces. Equipped with a positioner that moves the individual forks hydraulically. Grille for load protection and support included.

FCP 27T

59,500 lb	7'10"	4'8" (min.) - 7'10" (max.)	







FLOATING FORK CARRIAGE 66,100 LB WITH POSITIONER

ATT - 03 - 030

Fork carriage with a load capacity of 66,100 lb. The 7'10" extended length floating forks enable the load to be picked up even from uneven surfaces. Equipped with a positioner that moves the individual forks hydraulically. Grille for load protection and support included.

FCP 30T

			
66,100 lb	7'10"	4'5" (min.) - 6'6" (max.)	✓







FLOATING FORK CARRIAGE 66,100 LB, ADJUSTABLE WIDTH, WITH POSITIONER

ATT - 03 - 032

Fork carriage with a load capacity of 66,100 lb. The 7'10" extended length and lowered floating forks enable the load to be picked up even from uneven surfaces. Equipped with a positioner that moves the individual forks hydraulically. Grille for load protection and support included.

FCEP 30T 2,4 R

			
66,100 lb	7'10"	4'5" (min.) - 8'2" (max.)	✓







FLOATING FORK CARRIAGE 66,100 LB (WIDE) WITH POSITIONER AND SIDE SHIFT

ATT - 03 - 031

Fork carriage with a load capacity of 66,100 lb. The 7'10" extended length floating forks enable the load to be picked up even from uneven surfaces. Equipped with a positioner to hydraulically move the individual forks and a hydraulic side shift to slide them laterally, directly from the cab.

FCPT 30T 2,4 R

				
66,100 lb	7'10"	2'8" (min.) - 8'8" (max.)	+/- 1'	✓







FLOATING FORK CARRIAGE 77,100 LB WITH POSITIONER

ATT - 03 - 033

Fork carriage with a load capacity of 77,100 lb. The 7'10" extended length floating forks enable the load to be picked up even from uneven surfaces. Equipped with a positioner that moves the individual forks hydraulically. Grille for load protection and support included.

FCP 35T

			
77,100 lb	7'10"	4'7" (min.) - 6'8" (max.)	✓

COMPATIBILITY

	ATT-03-001	ATT-03-002	ATT-03-003	ATT-03-004	ATT-03-006	ATT-03-007	ATT-03-008
RTH 5.18	✓	✓	✓	✗	✓	×	✓
RTH 5.21	✓	✓	✓	✗	✓	×	✓
RTH 5.23	✓	✓	✓	✗	✓	×	✓
RTH 5.25	✓	✓	✓	✗	✓	×	✓
RTH 6.22	✓	✓	✓	✗	✓	×	✓
RTH 6.22 EC/TC	✓	✓	✓	✗	✓	×	✓
RTH 6.26	✓	✓	✓	✗	✓	×	✓
RTH 6.26 EC/TC	✓	✓	✓	✗	✓	×	✓
RTH 6.31	✓	✓	✓	✗	✓	×	✓
RTH 6.31 EC/TC	✓	✓	✓	✗	✓	×	✓
RTH 6.51	✓	✓	✓	✗	✓	×	✓
RTH 8.27	✓	✓	✓	✗	✓	×	✓
RTH 8.35	✓	✓	✓	✗	✓	×	✓
RTH 8.39	✓	✓	✓	✗	✓	×	✓
RTH 8.46	✓	✓	✓	✗	✓	✓	✓
RTH 10.37	✓	✓	✓	✗	✓	×	✓
RTH 13.26	✓	✓	✓	✗	✓	×	✓
TH 3.6	✗	✗	✗	✗	✗	✗	✗
TH 4,5.15	✗	✗	✗	✓	✗	✗	✗
TH 4,5.19	✗	✗	✗	✓	✗	✗	✗
TH 5.8	✗	✗	✗	✓	✗	✗	✗
TH 5,5.15	✗	✗	✗	✓	✗	✗	✗
TH 5,5.19	✗	✗	✗	✓	✗	✗	✗
TH 5,5.24	✗	✗	✗	✓	✗	✗	✗
TH 6.20	✗	✗	✗	✓	✗	✗	✗
TH 7.10	✗	✗	✗	✓	✗	✗	✗
HTH 10.10	✗	✗	✗	✗	✗	✗	✗
HTH 12.10	✗	✗	✗	✗	✗	✗	✗
HTH 16.10	✗	✗	✗	✗	✗	✗	✗
HTH 20.10	✗	✗	✗	✗	✗	✗	✗
HTH 25.11	✗	✗	✗	✗	✗	✗	✗
HTH 27.11	✗	✗	✗	✗	✗	✗	✗
HTH 30.12	✗	✗	✗	✗	✗	✗	✗
HTH 35.12	✗	✗	✗	✗	✗	✗	✗
HTH 50.14	✗	✗	✗	✗	✗	✗	✗

	ATT-03-009	ATT-03-010	ATT-03-011	ATT-03-013	ATT-03-014	ATT-03-15	ATT-03-016
RTH 5.18	✓	✓	✗	✗	✓	✓	✗
RTH 5.21	✓	✓	✗	✗	✓	✓	✗
RTH 5.23	✓	✓	✗	✗	✓	✓	✗
RTH 5.25	✓	✓	✗	✗	✓	✓	✗
RTH 6.22	✓	✓	✗	✗	✓	✓	✗
RTH 6.22 EC/TC	✓	✓	✗	✗	✓	✓	✗
RTH 6.26	✓	✓	✗	✗	✓	✓	✗
RTH 6.26 EC/TC	✓	✓	✗	✗	✓	✓	✗
RTH 6.31	✓	✓	✗	✗	✓	✓	✗
RTH 6.31 EC/TC	✓	✓	✗	✗	✓	✓	✗
RTH 6.51	✓	✓	✗	✗	✓	✓	✗
RTH 8.27	✓	✓	✗	✗	✓	✓	✗
RTH 8.35	✓	✓	✗	✗	✓	✓	✗
RTH 8.39	✓	✓	✗	✗	✓	✓	✗
RTH 8.46	✓	✓	✗	✗	✓	✓	✗
RTH 10.37	✓	✓	✗	✗	✓	✓	✗
RTH 13.26	✓	✓	✗	✗	✓	✓	✗
TH 3.6	✗	✗	✗	✗	✗	✗	✓
TH 4,5.15	✗	✗	✓	✗	✗	✗	✗
TH 4,5.19	✗	✗	✓	✗	✗	✗	✗
TH 5.8	✗	✗	✓	✗	✗	✗	✗
TH 5,5.15	✗	✗	✓	✗	✗	✗	✗
TH 5,5.19	✗	✗	✓	✗	✗	✗	✗
TH 5,5.24	✗	✗	✓	✗	✗	✗	✗
TH 6.20	✗	✗	✓	✗	✗	✗	✗
TH 7.10	✗	✗	✓	✗	✗	✗	✗
HTH 10.10	✗	✗	✗	✓	✗	✗	✗
HTH 12.10	✗	✗	✗	✓	✗	✗	✗
HTH 16.10	✗	✗	✗	✗	✗	✗	✗
HTH 20.10	✗	✗	✗	✗	✗	✗	✗
HTH 25.11	✗	✗	✗	✗	✗	✗	✗
HTH 27.11	✗	✗	✗	✗	✗	✗	✗
HTH 30.12	✗	✗	✗	✗	✗	✗	✗
HTH 35.12	✗	✗	✗	✗	✗	✗	✗
HTH 50.14	✗	✗	✗	✗	✗	✗	✗

✓: yes ✗: no

COMPATIBILITY

	ATT-03-017	ATT-03-018	ATT-03-019	ATT-03-020	ATT-03-021	ATT-03-022	ATT-03-023
RTH 5.18	✓	✗	✗	✗	✓	✗	✗
RTH 5.21	✓	✗	✗	✗	✓	✗	✗
RTH 5.23	✓	✗	✗	✗	✓	✗	✗
RTH 5.25	✓	✗	✗	✗	✓	✗	✗
RTH 6.22	✓	✗	✗	✗	✓	✗	✗
RTH 6.22 EC/TC	✓	✗	✗	✗	✓	✗	✗
RTH 6.26	✓	✗	✗	✗	✓	✗	✗
RTH 6.26 EC/TC	✓	✗	✗	✗	✓	✗	✗
RTH 6.31	✓	✗	✗	✗	✓	✗	✗
RTH 6.31 EC/TC	✓	✗	✗	✗	✓	✗	✗
RTH 6.51	✓	✗	✗	✗	✓	✗	✗
RTH 8.27	✓	✗	✗	✗	✓	✗	✗
RTH 8.35	✓	✗	✗	✗	✓	✗	✗
RTH 8.39	✓	✗	✗	✗	✓	✗	✗
RTH 8.46	✓	✗	✗	✗	✓	✗	✗
RTH 10.37	✓	✗	✗	✗	✓	✗	✗
RTH 13.26	✓	✗	✗	✗	✓	✗	✗
TH 3.6	✗	✗	✗	✗	✗	✗	✗
TH 4,5.15	✗	✗	✗	✗	✗	✗	✗
TH 4,5.19	✗	✗	✗	✗	✗	✗	✗
TH 5.8	✗	✗	✗	✗	✗	✗	✗
TH 5,5.15	✗	✗	✗	✗	✗	✗	✗
TH 5,5.19	✗	✗	✗	✗	✗	✗	✗
TH 5,5.24	✗	✗	✗	✗	✗	✗	✗
TH 6.20	✗	✗	✗	✗	✗	✗	✗
TH 7.10	✗	✗	✗	✗	✗	✗	✗
HTH 10.10	✗	✓	✓	✓	✓	✗	✗
HTH 12.10	✗	✓	✓	✓	✓	✗	✗
HTH 16.10	✗	✗	✗	✗	✗	✓	✓
HTH 20.10	✗	✗	✗	✗	✗	✓	✓
HTH 25.11	✗	✗	✗	✗	✗	✓	✓
HTH 27.11	✗	✗	✗	✗	✗	✓	✓
HTH 30.12	✗	✗	✗	✗	✗	✓	✓
HTH 35.12	✗	✗	✗	✗	✗	✓	✓
HTH 50.14	✗	✗	✗	✗	✗	✗	✗

	ATT-03-024	ATT-03-025	ATT-03-026	ATT-03-027	ATT-03-028	ATT-03-029
RTH 5.18	X	X	X	X	X	X
RTH 5.21	X	X	X	X	X	X
RTH 5.23	X	X	X	X	X	X
RTH 5.25	X	X	X	X	X	X
RTH 6.22	X	X	X	X	X	X
RTH 6.22 EC/TC	X	X	X	X	X	X
RTH 6.26	X	X	X	X	X	X
RTH 6.26 EC/TC	X	X	X	X	X	X
RTH 6.31	X	X	X	X	X	X
RTH 6.31 EC/TC	X	X	X	X	X	X
RTH 6.51	X	X	X	X	X	X
RTH 8.27	X	X	X	X	X	X
RTH 8.35	X	X	X	X	X	X
RTH 8.39	X	X	X	X	X	X
RTH 8.46	X	X	X	X	X	X
RTH 10.37	X	X	X	X	X	X
RTH 13.26	X	X	X	X	X	X
TH 3.6	X	X	X	X	X	X
TH 4,5.15	X	X	X	X	X	X
TH 4,5.19	X	X	X	X	X	X
TH 5.8	X	X	X	X	X	X
TH 5,5.15	X	X	X	X	X	X
TH 5,5.19	X	X	X	X	X	X
TH 5,5.24	X	X	X	X	X	X
TH 6.20	X	X	X	X	X	X
TH 7.10	X	X	X	X	X	X
HTH 10.10	X	X	X	X	X	X
HTH 12.10	X	X	X	X	X	X
HTH 16.10	✓	✓	✓	✓	✓	✓
HTH 20.10	✓	✓	✓	✓	✓	✓
HTH 25.11	✓	✓	✓	✓	✓	✓
HTH 27.11	✓	✓	✓	✓	✓	✓
HTH 30.12	✓	✓	✓	✓	✓	✓
HTH 35.12	✓	✓	✓	✓	✓	✓
HTH 50.14	X	X	X	X	X	X

✓: yes X: no

COMPATIBILITY

	ATT-03-030	ATT-03-031	ATT-03-032	ATT-03-033	ATT-03-034	ATT-03-036
RTH 5.18	X	X	X	X	X	X
RTH 5.21	X	X	X	X	X	X
RTH 5.23	X	X	X	X	X	X
RTH 5.25	X	X	X	X	X	X
RTH 6.22	X	X	X	X	X	X
RTH 6.22 EC/TC	X	X	X	X	X	X
RTH 6.26	X	X	X	X	X	X
RTH 6.26 EC/TC	X	X	X	X	X	X
RTH 6.31	X	X	X	X	X	X
RTH 6.31 EC/TC	X	X	X	X	X	X
RTH 6.51	X	X	X	X	X	X
RTH 8.27	X	X	X	X	X	X
RTH 8.35	X	X	X	X	X	X
RTH 8.39	X	X	X	X	X	X
RTH 8.46	X	X	X	X	X	X
RTH 10.37	X	X	X	X	X	X
RTH 13.26	X	X	X	X	X	X
TH 3.6	X	X	X	X	✓	X
TH 4,5.15	X	X	X	X	X	X
TH 4,5.19	X	X	X	X	X	X
TH 5.8	X	X	X	X	X	X
TH 5,5.15	X	X	X	X	X	X
TH 5,5.19	X	X	X	X	X	X
TH 5,5.24	X	X	X	X	X	X
TH 6.20	X	X	X	X	X	X
TH 7.10	X	X	X	X	X	X
HTH 10.10	X	X	X	X	X	✓
HTH 12.10	X	X	X	X	X	✓
HTH 16.10	✓	✓	✓	✓	X	X
HTH 20.10	✓	✓	✓	✓	X	X
HTH 25.11	✓	✓	✓	✓	X	X
HTH 27.11	✓	✓	✓	✓	X	X
HTH 30.12	✓	✓	✓	✓	X	X
HTH 35.12	✓	✓	✓	✓	X	X
HTH 50.14	X	X	X	X	X	X

	ATT-03-037	ATT-03-039	ATT-03-040	ATT-03-041	ATT-03-042	ATT-03-043
RTH 5.18	✓	✗	✗	✓	✗	✗
RTH 5.21	✓	✗	✗	✓	✗	✗
RTH 5.23	✓	✗	✗	✓	✗	✗
RTH 5.25	✓	✗	✗	✓	✗	✗
RTH 6.22	✓	✗	✗	✓	✗	✗
RTH 6.22 EC/TC	✓	✗	✗	✓	✗	✗
RTH 6.26	✓	✗	✗	✓	✗	✗
RTH 6.26 EC/TC	✓	✗	✗	✓	✗	✗
RTH 6.31	✓	✗	✗	✓	✗	✗
RTH 6.31 EC/TC	✓	✗	✗	✓	✗	✗
RTH 6.51	✓	✗	✗	✓	✗	✗
RTH 8.27	✓	✗	✗	✓	✗	✗
RTH 8.35	✓	✗	✗	✓	✗	✗
RTH 8.39	✓	✗	✗	✓	✗	✗
RTH 8.46	✓	✗	✗	✓	✗	✗
RTH 10.37	✓	✗	✗	✓	✗	✗
RTH 13.26	✓	✗	✗	✓	✗	✗
TH 3.6	✗	✗	✗	✗	✗	✗
TH 4,5.15	✗	✓	✓	✗	✓	✓
TH 4,5.19	✗	✓	✓	✗	✓	✓
TH 5.8	✗	✓	✓	✗	✓	✓
TH 5,5.15	✗	✓	✓	✗	✓	✓
TH 5,5.19	✗	✓	✓	✗	✓	✓
TH 5,5.24	✗	✓	✗	✗	✓	✓
TH 6.20	✗	✓	✗	✗	✗	✓
TH 7.10	✗	✓	✓	✗	✓	✓
HTH 10.10	✗	✗	✗	✗	✗	✗
HTH 12.10	✗	✗	✗	✗	✗	✗
HTH 16.10	✗	✗	✗	✗	✗	✗
HTH 20.10	✗	✗	✗	✗	✗	✗
HTH 25.11	✗	✗	✗	✗	✗	✗
HTH 27.11	✗	✗	✗	✗	✗	✗
HTH 30.12	✗	✗	✗	✗	✗	✗
HTH 35.12	✗	✗	✗	✗	✗	✗
HTH 50.14	✗	✗	✗	✗	✗	✗

✓: yes ✗: no

COMPATIBILITY

	ATT-03-044	ATT-03-045	ATT-03-046	ATT-03-047	ATT-03-048	ATT-03-049
RTH 5.18	X	X	X	✓	X	X
RTH 5.21	X	X	X	✓	X	X
RTH 5.23	X	X	X	✓	X	X
RTH 5.25	X	X	X	✓	X	X
RTH 6.22	X	X	X	✓	X	X
RTH 6.22 EC/TC	X	X	X	✓	X	X
RTH 6.26	X	X	X	✓	X	X
RTH 6.26 EC/TC	X	X	X	✓	X	X
RTH 6.31	X	X	X	✓	X	X
RTH 6.31 EC/TC	X	X	X	✓	X	X
RTH 6.51	X	X	X	✓	X	X
RTH 8.27	X	X	X	✓	X	X
RTH 8.35	X	X	X	✓	X	X
RTH 8.39	X	X	X	✓	X	X
RTH 8.46	X	X	X	✓	X	X
RTH 10.37	X	X	X	✓	X	X
RTH 13.26	X	X	X	✓	X	X
TH 3.6	X	X	X	X	X	X
TH 4,5.15	✓	✓	✓	X	✓	✓
TH 4,5.19	✓	✓	✓	X	✓	✓
TH 5.8	✓	✓	✓	X	✓	✓
TH 5,5.15	✓	✓	✓	X	✓	✓
TH 5,5.19	✓	✓	✓	X	✓	✓
TH 5,5.24	X	✓	✓	X	✓	✓
TH 6.20	X	✓	✓	X	X	✓
TH 7.10	✓	✓	✓	X	✓	✓
HTH 10.10	X	X	X	X	X	X
HTH 12.10	X	X	X	X	X	X
HTH 16.10	X	X	X	X	X	X
HTH 20.10	X	X	X	X	X	X
HTH 25.11	X	X	X	X	X	X
HTH 27.11	X	X	X	X	X	X
HTH 30.12	X	X	X	X	X	X
HTH 35.12	X	X	X	X	X	X
HTH 50.14	X	X	X	X	X	X

	ATT-03-050	ATT-03-051	ATT-03-052	ATT-03-053	ATT-03-054
RTH 5.18	X	X	X	X	X
RTH 5.21	X	X	X	X	X
RTH 5.23	X	X	X	X	X
RTH 5.25	X	X	X	X	X
RTH 6.22	X	X	X	X	X
RTH 6.22 EC/TC	X	X	X	X	X
RTH 6.26	X	X	X	X	X
RTH 6.26 EC/TC	X	X	X	X	X
RTH 6.31	X	X	X	X	X
RTH 6.31 EC/TC	X	X	X	X	X
RTH 6.51	X	X	X	X	X
RTH 8.27	X	X	X	X	X
RTH 8.35	X	X	X	X	X
RTH 8.39	X	X	X	X	X
RTH 8.46	X	X	X	X	X
RTH 10.37	X	X	X	X	X
RTH 13.26	X	X	X	X	X
TH 3.6	X	X	X	X	✓
TH 4,5.15	X	X	X	X	X
TH 4,5.19	X	X	X	X	X
TH 5.8	X	X	X	X	X
TH 5,5.15	X	X	X	X	X
TH 5,5.19	X	X	X	X	X
TH 5,5.24	X	X	X	X	X
TH 6.20	X	X	X	X	X
TH 7.10	X	X	X	X	X
HTH 10.10	✓	✓	✓	✓	X
HTH 12.10	✓	✓	✓	✓	X
HTH 16.10	X	X	X	X	X
HTH 20.10	X	X	X	X	X
HTH 25.11	X	X	X	X	X
HTH 27.11	X	X	X	X	X
HTH 30.12	X	X	X	X	X
HTH 35.12	X	X	X	X	X
HTH 50.14	X	X	X	X	X

✓: yes X: no

LATTICE BOOMS WITH/ WITHOUT WINCH

Precise and versatile, lattice booms are the ideal solution, whatever the job. They easily adapt to varying conditions, always offering the best solution to any problem.

Check the compatibility and capacity of each attachment with your dealer.







LATTICE BOOM WITH SINGLE PULL WINCH 1,750 LB



ATT - 04 - 005

Lattice boom with integral winch, extends the reach by an additional 5'7". Ideal for handling light and bulky loads, even in hard-to-reach areas. Maximum load capacity of 1,750 lb. Tubular structure to improve the weight/capacity ratio. The winch is equipped with a rope pressure roller and hydraulic limit switch system for rope raising/lowering.

JW 800

					
1,750 lb	23'11"	0.4"	98'5"	197 ft/min	✓



LATTICE BOOM WITH SINGLE PULL WINCH 2,000 LB



ATT - 04 - 028

Lattice boom with integral winch, extends the reach by an additional 12'7". Ideal for handling light and bulky loads, even in hard-to-reach areas. Maximum capacity of 2,000 lb. Tubular structure to improve the weight/capacity ratio. The winch is equipped with a rope pressure roller and hydraulic limit switch system for rope raising/lowering.

JW 900

					
2,000 lb	12'8"	0.4"	79/144 ft	157 / 79 ft/min	✓







LATTICE BOOM WITH SINGLE PULL WINCH 3,300 LB

ATT - 04 - 011

Lattice boom with integral winch, extends the reach by an additional 7'2". Ideal for handling light and bulky loads, even in hard-to-reach areas. Maximum capacity of 3,300 lb. Tubular structure to improve the weight/capacity ratio. The winch is equipped with a rope pressure roller and hydraulic limit switch system for rope raising/lowering.

JW 1500

					
3,300 lb	7'1"	0.4"	79'	171' ft/min	✓



LATTICE BOOM WITH DOUBLE PULL WINCH 4,400 LB

ATT - 04 - 015

Lattice boom with integral winch, extends the reach by an additional 6'7". Ideal for handling light and bulky loads, even in hard-to-reach areas. Maximum capacity of 4,400 lb. Tubular structure to improve the weight/capacity ratio. The winch is equipped with a rope pressure roller and hydraulic limit switch system for rope raising/lowering.

JW 2000

					
4,400 lb	7'10"	0.4"	79'	79 ft/min	✓







LATTICE BOOM WITH SINGLE PULL WINCH 6,000 LB

ATT - 04 - 017

Lattice boom with integral winch, extends the reach by an additional 5'7". Ideal for handling light and bulky loads, even in hard-to-reach areas. Maximum capacity of 6,000 lb. Tubular structure to improve the weight/capacity ratio. The winch is equipped with a rope pressure roller and hydraulic limit switch system for rope raising/lowering.

JW 2700

					
6,000 lb	5'7"	0.5"	164'	98 ft/min	✓



LATTICE BOOM WITH SINGLE PULL WINCH 6,600 LB

ATT - 04 - 019

Lattice boom with integral winch, extends the reach by an additional 5'7". Ideal for handling light and bulky loads, even in hard-to-reach areas. Maximum capacity of 6,600 lb. Tubular structure to improve the weight/capacity ratio. The winch is equipped with a rope pressure roller and hydraulic limit switch system for rope raising/lowering.

JW 3000





					
6,600 lb	5'7"	0.5"	164'	98 ft/min	✓

LATTICE BOOM WITH HOOK 1,300 LB

ATT - 04 - 001

Lattice boom with type-approved swivel hook that extends the reach by an additional 13'. Ideal for lifting light and bulky loads even in hard-to-reach areas. Maximum capacity of 1,300 lb. Tubular structure to improve the size/capacity ratio.





J 600		
 1,300 lb	 12'11"	 

BOX-SHAPED BOOM WITH HOOK 4,400 LB

ATT - 04 - 013

Double-T box-shaped boom with type-approved swivel hook that extends the reach by an additional 8'10". Ideal for lifting bulky loads of up to 4,400 lb even in hard-to-reach areas.



J 2000		
 4,400 lb	 9'9"	 



BOX-SHAPED BOOM WITH HOOK 8,800 LB

ATT - 04 - 024

Box-shaped boom with type-approved swivel hook that extends the reach by an additional 6'7". Ideal for lifting bulky loads of up to 8,800 lb even in hard-to-reach areas.

J 4000

<p>8,800 lb</p>	<p>6'7"</p>	<p>✓</p>



BOX-SHAPED BOOM WITH TWO HOOKS 4,400 LB - 15,400 LB

ATT - 04 - 027

Boom with 2 integral type-approved swivel hooks with a load capacity of 4,400/15,400 lb. The innermost hook has the larger load capacity, and allows the reach to be increased by an additional 9'3".

J 2000 / 7000

<p>4,400 / 15,400 lb</p>	<p>9'3"</p>	<p>✓</p>



LATTICE BOOM WITH WINCH, SINGLE PULL 1,750 LB / DOUBLE PULL 3,300 LB

ATT - 04 - 007

Lattice boom with integral winch, adjustable to two different lengths and load capacities. Fully extended, extends the reach by an additional 13' with a single pull load capacity of 1,750 lb. When used in the retracted configuration, at a length of 1,750/3,300 lb, the double pull load capacity can lift loads of up to 3,300 lb. Tubular structure to improve the weight/capacity ratio. The winch is equipped with a rope pressure roller and hydraulic limit switch system for rope raising/lowering.

JW 800/1500

1,750 / 3,300 lb	23'4" / 10'10"	0.4"	144' / 79'	157 / 79 ft/min	✓



HYDRAULIC TELESCOPIC BOOM WITH HOOK 3,300 LB / 5,500 LB

ATT - 04 - 021

Telescopic boom with box section adjustable to two different lengths and load capacities, equipped with a type-approved swivel hook. When fully extended, the reach is increased by a further 8'10" with a load capacity of 3,300 lb. When used fully retracted, the reach is 5'11", with load capacity increased to 5,500 lb.

JT 2500

5,500 lb (retracted) - 3,300 lb (extended)	5'10" (retracted) - 8'10" (extended)	3'3"	✓



LATTICE BOOM WITH WINCH, SINGLE PULL 2,650 LB / DOUBLE PULL 6,600 LB

ATT - 04 - 009

Lattice boom with integral winch, adjustable to two different lengths and load capacities. Fully extended, increases the reach by an additional 14'9" with a single pull load capacity of 2,650 lb. When used in the retracted configuration, at a length of 5'3", the double pull load capacity can lift loads of up to 6,600 lb. Tubular structure to improve the weight/capacity ratio. The winch is equipped with a rope pressure roller and hydraulic limit switch system for rope raising/lowering.

JW 1200/3000

2,650 / 6,600 lb	14'9" / 5'3"	0.4"	157' / 82'	157 / 79 ft/min	✓



SWAN-NECK BOOM WITH HOOK 6,600 LB

ATT - 04 - 023

Swan-neck boom equipped with a type-approved swivel hook that extends the reach by an additional 4'11". Ideal for handling loads of up to 6,600 lb even in confined spaces, attics and plant nurseries.

JCC 3000



6,600 lb	-	3'6"	✓



BOX-SHAPED BOOM WITH HOOK 17,600 LB

ATT - 04 - 026

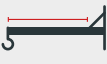
Box-shaped boom with type-approved swivel hook that extends the reach by an additional 10'. Ideal for lifting bulky loads of up to 17,600 lb even in hard-to-reach areas.



J 8000		
		
17,600 lb	10'7"	✓



BOOM WITH 3 HOOKS, 44,100 LB - 33,100 LB - 22,000 LB

ATT - 04 - 008

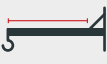
Boom with 3 integral type-approved swivel hooks with a load capacity of 22,000/33,100/44,100 lb. The innermost hook has the largest load capacity, and allows the reach to be increased by an additional 6'7".

J 20 S-3		
		
22,000 / 33,100 / 44,100 lb	7'4"	✓

COMPATIBILITY

	ATT-04-001	ATT-04-005	ATT-04-007	ATT-04-008	ATT-04-009	ATT-04-011	ATT-04-013	ATT-04-015
RTH 5.18	✓	✓	✓	✗	✓	✓	✓	✓
RTH 5.21	✓	✓	✓	✗	✓	✓	✓	✓
RTH 5.23	✓	✓	✓	✗	✓	✓	✓	✓
RTH 5.25	✓	✓	✓	✗	✓	✓	✓	✓
RTH 6.22	✓	✓	✓	✗	✓	✓	✓	✓
RTH 6.22 EC/TC	✓	✓	✓	✗	✓	✓	✓	✓
RTH 6.26	✓	✓	✓	✗	✓	✓	✓	✓
RTH 6.26 EC/TC	✓	✓	✓	✗	✓	✓	✓	✓
RTH 6.31	✓	✓	✓	✗	✓	✓	✓	✓
RTH 6.31 EC/TC	✓	✓	✓	✗	✓	✓	✓	✓
RTH 6.51	✓	✓	✓	✗	✓	✓	✓	✓
RTH 8.27	✓	✓	✓	✗	✓	✓	✓	✓
RTH 8.35	✓	✓	✓	✗	✓	✓	✓	✓
RTH 8.39	✓	✓	✓	✗	✓	✓	✓	✓
RTH 8.46	✓	✓	✓	✗	✓	✓	✓	✓
RTH 10.37	✓	✓	✓	✗	✓	✓	✓	✓
RTH 13.26	✓	✓	✓	✗	✓	✓	✓	✓
TH 3.6	✗	✗	✗	✗	✗	✗	✗	✗
TH 4,5.15	✓	✗	✗	✗	✓	✓	✓	✓
TH 4,5.19	✓	✗	✗	✗	✓	✓	✓	✓
TH 5.8	✓	✗	✗	✗	✓	✓	✓	✓
TH 5,5.15	✓	✗	✗	✗	✓	✓	✓	✓
TH 5,5.19	✓	✗	✗	✗	✓	✓	✓	✓
TH 5,5.24	✓	✗	✗	✗	✓	✓	✓	✓
TH 6.20	✓	✗	✗	✗	✓	✓	✓	✓
TH 7.10	✓	✗	✗	✗	✓	✓	✓	✓
HTH 10.10	✓	✗	✗	✗	✓	✓	✓	✓
HTH 12.10	✓	✗	✗	✗	✓	✓	✓	✓
HTH 16.10	✗	✗	✗	✓	✗	✗	✗	✗
HTH 20.10	✗	✗	✗	✓	✗	✗	✗	✗
HTH 25.11	✗	✗	✗	✓	✗	✗	✗	✗
HTH 27.11	✗	✗	✗	✓	✗	✗	✗	✗
HTH 30.12	✗	✗	✗	✓	✗	✗	✗	✗
HTH 35.12	✗	✗	✗	✓	✗	✗	✗	✗
HTH 50.14	✗	✗	✗	✗	✗	✗	✗	✗

	ATT-04-017	ATT-04-019	ATT-04-021	ATT-04-023	ATT-04-24	ATT-04-026	ATT-04-027	ATT-04-028
RTH 5.18	✓	✓	✓	✓	✓	✗	✓	✓
RTH 5.21	✓	✓	✓	✓	✓	✗	✓	✓
RTH 5.23	✓	✓	✓	✓	✓	✗	✓	✓
RTH 5.25	✓	✓	✓	✓	✓	✗	✓	✓
RTH 6.22	✓	✓	✓	✓	✓	✗	✓	✓
RTH 6.22 EC/TC	✓	✓	✓	✓	✓	✗	✓	✓
RTH 6.26	✓	✓	✓	✓	✓	✗	✓	✓
RTH 6.26 EC/TC	✓	✓	✓	✓	✓	✗	✓	✓
RTH 6.31	✓	✓	✓	✓	✓	✗	✓	✓
RTH 6.31 EC/TC	✓	✓	✓	✓	✓	✗	✓	✓
RTH 6.51	✓	✓	✓	✓	✓	✗	✓	✓
RTH 8.27	✓	✓	✓	✓	✓	✗	✓	✓
RTH 8.35	✓	✓	✓	✓	✓	✗	✓	✓
RTH 8.39	✓	✓	✓	✓	✓	✗	✓	✓
RTH 8.46	✓	✓	✓	✓	✓	✗	✓	✓
RTH 10.37	✓	✓	✓	✓	✓	✗	✓	✓
RTH 13.26	✓	✓	✓	✓	✓	✗	✓	✓
TH 3.6	✗	✗	✗	✗	✗	✗	✗	✗
TH 4,5.15	✓	✓	✓	✓	✓	✗	✓	✓
TH 4,5.19	✓	✓	✓	✓	✓	✗	✓	✓
TH 5.8	✓	✓	✓	✓	✓	✗	✓	✓
TH 5,5.15	✓	✓	✓	✓	✓	✗	✓	✓
TH 5,5.19	✓	✓	✓	✓	✓	✗	✓	✓
TH 5,5.24	✓	✓	✓	✓	✓	✗	✓	✓
TH 6.20	✓	✓	✓	✓	✓	✗	✓	✓
TH 7.10	✓	✓	✓	✓	✓	✗	✓	✓
HTH 10.10	✓	✓	✓	✓	✓	✗	✗	✓
HTH 12.10	✓	✓	✓	✓	✓	✗	✗	✓
HTH 16.10	✗	✗	✗	✗	✗	✓	✗	✗
HTH 20.10	✗	✗	✗	✗	✗	✓	✗	✗
HTH 25.11	✗	✗	✗	✗	✗	✓	✗	✗
HTH 27.11	✗	✗	✗	✗	✗	✓	✗	✗
HTH 30.12	✗	✗	✗	✗	✗	✓	✗	✗
HTH 35.12	✗	✗	✗	✗	✗	✓	✗	✗
HTH 50.14	✗	✗	✗	✗	✗	✗	✗	✗

✓: yes ✗: no

HOOKS



Simple and yet extremely versatile and durable, Magni type-approved hooks have a vast range of applications in construction. The range includes hooks of various load capacities in response to specific requirements, always with the best performance.

Check the compatibility and capacity of each attachment with your dealer.



HOOK 6,600 LB

ATT - 05 - 004

Type-approved 360° swivel hook with safety catch, designed for handling suspended loads. Load capacity up to 6,600 lb. Metal storage support included.

HS 3

<p>6,600 lb</p>	<p>1'5"</p>	<p>✓</p>	<p>✓</p>



HOOK 11,000 LB

ATT - 05 - 014

Type-approved 360° swivel hook with safety catch, designed for handling suspended loads. Load capacity up to 11,000 lb. Metal storage support included.

H 5

<p>11,000 lb</p>	<p>1'7"</p>	<p>✓</p>	<p>✓</p>



HOOK 13,200 LB

ATT - 05 - 001

Type-approved 360° swivel hook with safety catch, designed for handling suspended loads. Load capacity up to 13,200 lb. Metal storage support included.

H 6

			
13,200 lb	1'7"	✓	✓



HOOK 15,400 LB

ATT - 05 - 002

Type-approved 360° swivel hook with safety catch, designed for handling suspended loads. Load capacity up to 15,400 lb. Metal storage support included.

H 7

			
15,400 lb	1'2"	✓	✓



HOOK 17,600 LB

ATT - 05 - 003

Type-approved 360° swivel hook with safety catch, designed for handling suspended loads. Load capacity up to 17,600 lb. Metal storage support included.

H 8

			
17,600 lb	2'11"	✓	✓



HOOK 22,000 LB

ATT - 05 - 005

Type-approved 360° swivel hook with safety catch, designed for handling suspended loads. Load capacity up to 22,000 lb. Metal storage support included.

H 10

			
22,000 lb	1'2"	✓	✓



HOOK 28,600 LB

ATT - 05 - 013

Type-approved 360° swivel hook with safety catch. Its compact design and load capacity of up to 28,600 lb make it ideal for transporting the heaviest suspended loads.

H 13

28,600 lb	11"	✓	✓



HOOK 35,300 LB

ATT - 05 - 007

Type-approved 360° swivel hook with safety catch. Its compact design and load capacity of up to 35,300 lb make it ideal for transporting the heaviest suspended loads.

H 16S

35,300 lb	1'8"	✓	✓





HOOK 44,100 LB

ATT - 05 - 008

Type-approved 360° swivel hook with safety catch. Its compact design and load capacity of up to 44,100 lb make it ideal for transporting the heaviest suspended loads.

H 20S

			
44,100 lb	1'8"	✓	✓



HOOK 67,200 LB

ATT - 05 - 009

Type-approved 360° swivel hook with safety catch. Its compact design and load capacity of up to 67,200 lb make it ideal for transporting the heaviest suspended loads.

H 30S

			
67,200 lb	1'4"	+/- 30°	✓





HOOK 488,100 LB (NARROW)

ATT - 05 - 011

Type-approved 360° swivel hook with safety catch. Its compact design and load capacity of up to 88,100 lb make it ideal for transporting the heaviest suspended loads.

H 40S

			
88,100 lb	1'4"	+/- 30°	✓



HOOK 110,200 LB

ATT - 05 - 012

Type-approved 360° swivel hook with safety catch. Its compact design and load capacity of up to 110,200 lb make it ideal for transporting the heaviest suspended loads.

H 50

			
110,200 lb	2'6"	+/- 30°	✓

COMPATIBILITY

	ATT-05-001	ATT-05-002	ATT-05-003	ATT-05-004	ATT-05-005	ATT-05-007
RTH 5.18	✓	✗	✓	✗	✓	✗
RTH 5.21	✓	✗	✓	✗	✓	✗
RTH 5.23	✓	✗	✓	✗	✓	✗
RTH 5.25	✓	✗	✓	✗	✓	✗
RTH 6.22	✓	✗	✓	✗	✓	✗
RTH 6.22 EC/TC	✓	✗	✓	✗	✓	✗
RTH 6.26	✓	✗	✓	✗	✓	✗
RTH 6.26 EC/TC	✓	✗	✓	✗	✓	✗
RTH 6.31	✓	✗	✓	✗	✓	✗
RTH 6.31 EC/TC	✓	✗	✓	✗	✓	✗
RTH 6.51	✓	✗	✓	✗	✓	✗
RTH 8.27	✓	✗	✓	✗	✓	✗
RTH 8.35	✓	✗	✓	✗	✓	✗
RTH 8.39	✓	✗	✓	✗	✓	✗
RTH 8.46	✓	✗	✓	✗	✓	✗
RTH 10.37	✓	✗	✓	✗	✓	✗
RTH 13.26	✓	✗	✓	✗	✓	✗
TH 3.6	✗	✗	✗	✓	✗	✗
TH 4,5.15	✓	✓	✗	✗	✗	✗
TH 4,5.19	✓	✓	✗	✗	✗	✗
TH 5.8	✓	✓	✗	✗	✗	✗
TH 5,5.15	✓	✓	✗	✗	✗	✗
TH 5,5.19	✓	✓	✗	✗	✗	✗
TH 5,5.24	✓	✓	✗	✗	✗	✗
TH 6.20	✓	✓	✗	✗	✗	✗
TH 7.10	✓	✓	✗	✗	✗	✗
HTH 10.10	✓	✗	✗	✗	✓	✗
HTH 12.10	✓	✗	✗	✗	✓	✗
HTH 16.10	✗	✗	✗	✗	✗	✓
HTH 20.10	✗	✗	✗	✗	✗	✓
HTH 25.11	✗	✗	✗	✗	✗	✓
HTH 27.11	✗	✗	✗	✗	✗	✓
HTH 30.12	✗	✗	✗	✗	✗	✓
HTH 35.12	✗	✗	✗	✗	✗	✓
HTH 50.14	✗	✗	✗	✗	✗	✗

	ATT-05-008	ATT-05-009	ATT-05-011	ATT-05-012	ATT-05-013	ATT-05-014
RTH 5.18	X	X	X	X	✓	✓
RTH 5.21	X	X	X	X	✓	✓
RTH 5.23	X	X	X	X	✓	✓
RTH 5.25	X	X	X	X	✓	✓
RTH 6.22	X	X	X	X	✓	✓
RTH 6.22 EC/TC	X	X	X	X	✓	✓
RTH 6.26	X	X	X	X	✓	✓
RTH 6.26 EC/TC	X	X	X	X	✓	✓
RTH 6.31	X	X	X	X	✓	✓
RTH 6.31 EC/TC	X	X	X	X	✓	✓
RTH 6.51	X	X	X	X	✓	✓
RTH 8.27	X	X	X	X	✓	✓
RTH 8.35	X	X	X	X	✓	✓
RTH 8.39	X	X	X	X	✓	✓
RTH 8.46	X	X	X	X	✓	✓
RTH 10.37	X	X	X	X	✓	✓
RTH 13.26	X	X	X	X	✓	✓
TH 3.6	X	X	X	X	X	X
TH 4,5.15	X	X	X	X	X	✓
TH 4,5.19	X	X	X	X	X	✓
TH 5.8	X	X	X	X	X	✓
TH 5,5.15	X	X	X	X	X	✓
TH 5,5.19	X	X	X	X	X	✓
TH 5,5.24	X	X	X	X	X	✓
TH 6.20	X	X	X	X	X	✓
TH 7.10	X	X	X	X	X	✓
HTH 10.10	X	X	X	X	✓	X
HTH 12.10	X	X	X	X	✓	X
HTH 16.10	✓	✓	✓	✓	X	X
HTH 20.10	✓	✓	✓	✓	X	X
HTH 25.11	✓	✓	✓	✓	X	X
HTH 27.11	✓	✓	✓	✓	X	X
HTH 30.12	✓	✓	✓	✓	X	X
HTH 35.12	✓	✓	✓	✓	X	X
HTH 50.14	X	X	X	X	X	X

✓: yes X: no

CLAMPS



Designed specifically for mining and quarrying applications, as well as the logistics sector, our clamps offer unrivalled versatility and performance. The range has been specifically designed to handle even the toughest conditions.

Check the compatibility and capacity of each attachment with your dealer.



RIBS CLAMP 8,800 LB

ATT - 06 - 001

Clamp with a load capacity of 8,800 lb, made of high-strength material, for installing supporting arch ribs in tunnel construction applications. 65° rotation and 46° tilt for precise rib installation.

RC 4T

			
<p>8,800 lb</p>	<p>46°</p>	<p>+/- 65° (manual)</p>	<p>✓</p>



3D-FILM HANDLER 5,500 LB

ATT - 06 - 002

The 3D-Film handler is designed for the film industry, and features a surface designed to support equipment like LED panels or light diffusers during studio and location shoots. It has a load capacity of 5,500 lb and offers a full 360° of rotation.

3DF 2,5

			
<p>5,500 lb</p>	<p>360°</p>	<p>360°</p>	<p>✓</p>

TYRE HANDLER 5,500 LB - 25"

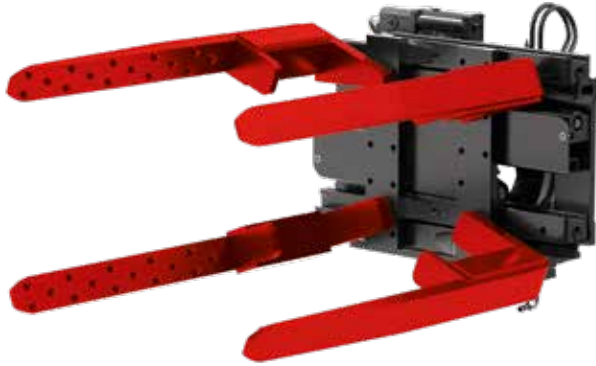







ATT - 06 - 003

Tyre handler with a load capacity of 5,500 lb, ideal for handling tyres from 4' to 7'8" diameter. Hydraulic opening/closing, can be rotated through 360°. Non-slip forks assure that the tyre is held securely. OPT-02-022 "Double hydraulic output at the boom head", required to use the clamp, must be ordered separately

CHECK FOR ANY PREARRANGEMENT REQUIREMENTS

TC 2,5.25

					
5,500 lb	4'	7'8"	360°	✗	✓

TYRE HANDLER 8,400 LB - 49"









ATT - 06 - 005

Tyre handler with a load capacity of 8,400 lb, ideal for handling tyres from 5'2" to 10'3" diameter. Hydraulic opening/closing, can be rotated through 360°. Non-slip forks assure that the tyre is held securely. OPT-02-022 "Double hydraulic output at the boom head", required to use the clamp, must be ordered separately

CHECK FOR ANY PREARRANGEMENT REQUIREMENTS

TC 3,8.49

					
8,400 lb	5'2"	10'3"	360°	✗	✓



PIPES HANDLER 2,200 LB

ATT - 06 - 009

Clamp for handling pipes, load capacity up to 2,200 lb, pipe diameter from 9.5" up to 1'11". The clamp has three degrees of freedom; 360° rotation, +/- 5.9" sideshift, and clamp opening/closing.



PC 1000

					
2,200 lb	9.5"	1'11"	+/- 5.9"	360°	✓





CYLINDER HANDLER 10,000 LB

ATT - 06 - 011

Clamp with a load capacity of 10,000 lb, ideal for handling various types of cylinder of diameters from 9.8" up to 1'6". Four different movements: clamp opening/closing, +/- 11.8" sideshift, 360° rotation and +/- 27° lateral rotation of the cylinder.



CC 4.5

							
10,000 lb	14'6" - 7'6"	7'6" (max.) 8'11" (min)	1'6"	+/- 11.8"	360°	+/- 27°	✓







TYRE HANDLER 17,600 LB - 63"

ATT - 06 - 006



Tyre handler with a load capacity of 17,600 lb, ideal for handling tyres from 3'11" to 13'1" diameter. Hydraulic opening/closing, the pads can be rotated through 360°. The unit also has +/- 11.8" side shift and 344° rotation in both directions. The clamp is also equipped with extensions which stop the tyre sliding inwards once it is clamped.

TC 08.63

						
17,600 lb	3'10"	13'1"	344°	360°	+/- 11.8"	✓







TYRE HANDLER 35,300 LB - 63"

ATT - 06 - 007



Tyre handler with a load capacity of 35,300 lb, ideal for handling tyres from 3'11" to 13'11" diameter. Hydraulic opening/closing, the pads can be rotated through 360°. The unit also has +/- 11.8" side shift and 344° rotation in both directions. The clamp is also equipped with hydraulic extensions which stop the tyre sliding inwards once it is clamped.

TC 16.63 CP

						
35,300 lb	3'10"	13'11"	344°	360°	+/- 11.8"	✓







CYLINDER HANDLER 24,250 LB



ATT - 06 - 010

Clamp for servicing, replacing and handling large excavator cylinders weighing up to 24,250 lb, with a diameter up to 2'0.4". This attachment requires the MTM, which must be ordered separately. (ATT-08-004).

CHECK FOR ANY PREARRANGEMENT REQUIREMENTS







CC						
						
24,250 lb	9'8" - 3'2"	19'0.3" (max.) 9'1" (min)	2'0.4" MAX.	+/- 11.8"	360°	✓

CYLINDER HANDLER 10,000 LB



ATT - 06 - 012

Clamp with a load capacity of 10,000 lb, ideal for handling various types of cylinder of diameters from 9.8" up to 1'6". Four different movements: clamp opening/closing, +/- 11.8" side shift, 360° rotation and +/- 27° lateral rotation of the cylinder.

CC 4.5						
						
10,000 lb	14'6" - 7'6"	13'10" (max.) 8'11" (min)	1'6" MAX.	+/- 1.8"	360°	+/- 27°







TYRE HANDLER 7,700 LB - 55"

ATT - 06 - 004

Tyre handler with a load capacity of 7,700 lb, ideal for handling tyres from 3'8" to 11'6" diameter. Hydraulic opening/closing, the pads can be rotated through +/-61°. The unit also has +/-24° rotation in both directions. The clamp is also equipped with extensions which stop the tyre sliding inwards once it is clamped.



TC 3,5

					
7,700 lb	3'8"	11'6"	+/- 24°	+/- 61°	✓

COMPATIBILITY

	ATT-06-001	ATT-06-002	ATT-06-003	ATT-06-004	ATT-06-005	ATT-06-006
RTH 5.18	✓	✓	✓	✗	✓	✗
RTH 5.21	✓	✓	✓	✗	✓	✗
RTH 5.23	✓	✓	✓	✗	✓	✗
RTH 5.25	✓	✓	✓	✗	✓	✗
RTH 6.22	✓	✓	✓	✗	✓	✗
RTH 6.22 EC/TC	✓	✓	✓	✗	✓	✗
RTH 6.26	✓	✓	✓	✗	✓	✗
RTH 6.26 EC/TC	✓	✓	✓	✗	✓	✗
RTH 6.31	✓	✓	✓	✗	✓	✗
RTH 6.31 EC/TC	✓	✓	✓	✗	✓	✗
RTH 6.51	✓	✓	✓	✗	✓	✗
RTH 8.27	✓	✓	✓	✗	✓	✗
RTH 8.35	✓	✓	✓	✗	✓	✗
RTH 8.39	✓	✓	✓	✗	✓	✗
RTH 8.46	✓	✓	✓	✗	✓	✗
RTH 10.37	✓	✓	✓	✗	✓	✗
RTH 13.26	✓	✓	✓	✗	✓	✗
TH 3.6	✗	✗	✗	✗	✗	✗
TH 4,5.15	✓	✓	✓	✗	✓	✗
TH 4,5.19	✓	✓	✓	✗	✓	✗
TH 5.8	✓	✓	✓	✗	✓	✗
TH 5,5.15	✓	✓	✓	✗	✓	✗
TH 5,5.19	✓	✓	✓	✗	✓	✗
TH 5,5.24	✓	✓	✓	✗	✓	✗
TH 6.20	✓	✓	✓	✗	✓	✗
TH 7.10	✓	✓	✓	✗	✓	✗
HTH 10.10	✗	✓	✓	✓	✓	✗
HTH 12.10	✗	✓	✓	✓	✓	✗
HTH 16.10	✗	✗	✗	✗	✗	✓
HTH 20.10	✗	✗	✗	✗	✗	✓
HTH 25.11	✗	✗	✗	✗	✗	✓
HTH 27.11	✗	✗	✗	✗	✗	✓
HTH 30.12	✗	✗	✗	✗	✗	✓
HTH 35.12	✗	✗	✗	✗	✗	✓
HTH 50.14	✗	✗	✗	✗	✗	✗

	ATT-06-007	ATT-06-009	ATT-06-010	ATT-06-011	ATT-06-012
RTH 5.18	X	✓	X	✓	X
RTH 5.21	X	✓	X	✓	X
RTH 5.23	X	✓	X	✓	X
RTH 5.25	X	✓	X	✓	X
RTH 6.22	X	✓	X	✓	X
RTH 6.22 EC/TC	X	✓	X	✓	X
RTH 6.26	X	✓	X	✓	X
RTH 6.26 EC/TC	X	✓	X	✓	X
RTH 6.31	X	✓	X	✓	X
RTH 6.31 EC/TC	X	✓	X	✓	X
RTH 6.51	X	✓	X	✓	X
RTH 8.27	X	✓	X	✓	X
RTH 8.35	X	✓	X	✓	X
RTH 8.39	X	✓	X	✓	X
RTH 8.46	X	✓	X	✓	X
RTH 10.37	X	✓	X	✓	X
RTH 13.26	X	✓	X	✓	X
TH 3.6	X	X	X	X	X
TH 4,5.15	X	✓	X	X	X
TH 4,5.19	X	✓	X	X	X
TH 5.8	X	✓	X	X	X
TH 5,5.15	X	✓	X	X	X
TH 5,5.19	X	✓	X	X	X
TH 5,5.24	X	✓	X	X	X
TH 6.20	X	✓	X	X	X
TH 7.10	X	✓	X	X	X
HTH 10.10	X	✓	X	✓	X
HTH 12.10	X	✓	X	✓	X
HTH 16.10	✓	X	✓	X	✓
HTH 20.10	✓	X	✓	X	✓
HTH 25.11	✓	X	✓	X	✓
HTH 27.11	✓	X	✓	X	✓
HTH 30.12	✓	X	✓	X	✓
HTH 35.12	✓	X	✓	X	✓
HTH 50.14	X	X	X	X	X

✓: yes X: no

BUCKETS



Developed for the construction and maintenance sectors, our buckets are available in a range of lifting capacities, and are known as reliable partners in any industrial application. Like all our attachments, they offer Magni's guaranteed performance and quality.

Check the compatibility and capacity of each attachment with your dealer.



BUCKET 2.62 YD³

ATT - 07 - 003

Bucket with dedicated heavy-duty range mounting and robust construction, offering 2.62 yd³ capacity. Equipped with a bolt-on, reversible cutting edge for extended service life and easy replacement. Suitable for handling aggregates such as sand, gravel, expanded clay and generally any granular material.

CB 2000

			
2.74 yd ³	2.17 yd ³	8'1"	✓



BUCKET 3.92 YD³

ATT - 07 - 004

Robust bucket with wear-resistant blade and a capacity of 3.92 yd³. Designed for easy loading/unloading. Suitable for moving aggregates such as sand and gravel around the worksite.

CB 3000

			
4.05 yd ³	3.21 yd ³	9'10"	✓



BUCKET WITH BOLT-ON CUTTING EDGE 1.31 YD³

ATT - 07 - 015

Lightweight bucket with a capacity of 1.31 yd³. Equipped with a bolt-on, reversible cutting edge for extended service life and easy replacement. Suitable for handling aggregates such as sand, gravel, expanded clay and generally any granular material.

CB 1000 DL

			
1.31 yd ³	1.08 yd ³	8'1"	✓



BUCKET WITH BOLT-ON CUTTING EDGE 1.96 YD³

ATT - 07 - 016

Lightweight bucket with a capacity of 1.96 yd³. Equipped with a bolt-on, reversible cutting edge for extended service life and easy replacement. Suitable for handling aggregates such as sand, gravel, expanded clay and generally any granular material.

CB 1500 DL

			
1.96 yd ³	1.55 yd ³	8'0.4"	✓



BUCKET WITH BOLT-ON CUTTING EDGE 2.62 YD³

ATT - 07 - 018

Lightweight bucket with a capacity of 2.62 yd³. Equipped with a bolt-on, reversible cutting edge for extended service life and easy replacement. Suitable for handling aggregates such as sand, gravel, expanded clay and generally any granular material.

CB 2000 DL

			
2.62 yd ³	2.13 yd ³	8'0.4"	✓



REINFORCED BUCKET WITH BOLT-ON CUTTING EDGE 1.96 YD³

ATT - 07 - 010

Robust bucket with a capacity of 1.96 yd³. Equipped with a bolt-on, reversible cutting edge for extended service life and easy replacement. Suitable for handling aggregates such as sand, gravel, expanded clay and generally any granular material.

CB 1500

			
1.96 yd ³	1.55 yd ³	8'0.4"	✓



REINFORCED BUCKET WITH BOLT-ON CUTTING EDGE, 2.62 YD³

ATT - 07 - 011

Robust bucket with a capacity of 2.62 yd³. Equipped with a bolt-on, reversible cutting edge for extended service life and easy replacement. Suitable for handling aggregates such as sand, gravel, expanded clay and generally any granular material.

CB 2000

			
2.76 yd ³	2.19 yd ³	8'1"	✓



REINFORCED BUCKET WITH BOLT-ON CUTTING EDGE, 3.27 YD³

ATT - 07 - 012

Robust bucket with a capacity of 3.27 yd³. Equipped with a bolt-on, reversible cutting edge for extended service life and easy replacement. Suitable for handling aggregates such as sand, gravel, expanded clay and generally any granular material.

CB 2500

			
3.31 yd ³	2.63 yd ³	8'0.4"	✓



BUCKET WITH WELDED CUTTING EDGE 1.31 YD³

ATT - 07 - 013

Lightweight bucket with a capacity of 1.31 yd³. Equipped with welded cutting edge. Suitable for handling aggregates such as sand, gravel, expanded clay and generally any granular material.

CB 1000 SL

			
1.31 yd ³	1.08 yd ³	8'0.4"	✓



BUCKET WITH WELDED CUTTING EDGE 1.96 YD³

ATT - 07 - 014

Lightweight bucket with a capacity of 1.96 yd³. Equipped with welded cutting edge. Suitable for handling aggregates such as sand, gravel, expanded clay and generally any granular material.

CB 1500 SL

			
1.96 yd ³	1.55 yd ³	8'0.4"	✓





BUCKET WITH WELDED CUTTING EDGE 2.62 YD³

ATT - 07 - 017

Lightweight bucket with a capacity of 2.62 yd³. Equipped with welded cutting edge. Suitable for handling aggregates such as sand, gravel, expanded clay and generally any granular material.

CB 2000 SL

			
2.62 yd ³	2.13 yd ³	8'0.4"	✓





REINFORCED BUCKET WITH WELDED CUTTING EDGE 1.31 YD³

ATT - 07 - 019

Robust bucket with a capacity of 1.31 yd³. Equipped with a welded cutting edge, it is suitable for handling aggregates such as sand, gravel, expanded clay and generally any granular material.

CB 1000

			
1.31 yd ³	1.08 yd ³	8'0.4"	✓



REINFORCED BUCKET WITH WELDED CUTTING EDGE 1.96 YD³

ATT - 07 - 020

Robust bucket with a capacity of 1.96 yd³. Equipped with a welded cutting edge, it is suitable for handling aggregates such as sand, gravel, expanded clay and generally any granular material.

CB 1500

			
1.96 yd ³	1.56 yd ³	8'0.4"	✓



AGGREGATE CONTAINER 2.62 YD³

ATT - 07 - 007

Aggregates bucket with 2.62 yd³ capacity. Ideal for loading bulk materials onto trucks.

BIM 2000

			
2.68 yd ³	1.96 yd ³	7'11"	✓



BUCKET 1.11 YD³ (4X1)

ATT - 07 - 009

This bucket is used for levelling and unloading jobs: when the clamp is closed and the bucket tilted forwards, it digs into the ground and fills with material for loading directly into the dump truck. Can also be used to pick up materials or objects or as a bulldozer, with the clamp chassis completely open, using the bucket frame to push material forwards one layer at a time.

4X1 850L

			
1.11 yd ³	0.88 yd ³	7'10"	✓



BUCKET 7.72 YD³ (4X1)

ATT - 07 - 006

Versatile four-in-one bucket for a variety of on-site applications. Ideal for collecting material with a density $\leq 0,13$ lb/ft³. The sides are fitted with teeth for securely gripping cylindrical objects. Rear blade for terrain levelling and recovery.

4X1 5900

			
7.69 yd ³	6.17 yd ³	8'2"	✓



BUCKET WITH WELDED CUTTING EDGE 1.05 YD³

ATT - 07 - 005

Lightweight bucket with a capacity of 1.05 yd³. Equipped with a welded cutting edge, it is suitable for handling aggregates such as sand, gravel, expanded clay and generally any granular material.

CB 1500		
		
1.05 yd ³	0.84 yd ³	6'2"



COMPATIBILITY

	ATT-07-003	ATT-07-004	ATT-07-005	ATT-07-006	ATT-07-007	ATT-07-009	ATT-07-010	ATT-07-011	ATT-07-012
RTH 5.18	X	X	X	X	✓	✓	X	X	X
RTH 5.21	X	X	X	X	✓	✓	X	X	X
RTH 5.23	X	X	X	X	✓	✓	X	X	X
RTH 5.25	X	X	X	X	✓	✓	X	X	X
RTH 6.22	X	X	X	X	✓	✓	X	X	X
RTH 6.22 EC/TC	X	X	X	X	✓	✓	X	X	X
RTH 6.26	X	X	X	X	✓	✓	X	X	X
RTH 6.26 EC/TC	X	X	X	X	✓	✓	X	X	X
RTH 6.31	X	X	X	X	✓	✓	X	X	X
RTH 6.31 EC/TC	X	X	X	X	✓	✓	X	X	X
RTH 6.51	X	X	X	X	✓	✓	X	X	X
RTH 8.27	X	X	X	X	✓	✓	X	X	X
RTH 8.35	X	X	X	X	✓	✓	X	X	X
RTH 8.39	X	X	X	X	✓	✓	X	X	X
RTH 8.46	X	X	X	X	✓	✓	X	X	X
RTH 10.37	X	X	X	X	✓	✓	X	X	X
RTH 13.26	X	X	X	X	✓	✓	X	X	X
TH 3.6	X	X	✓	X	X	X	X	X	X
TH 4,5.15	X	X	X	X	X	✓	✓	✓	✓
TH 4,5.19	X	X	X	X	X	✓	✓	✓	✓
TH 5.8	X	X	X	X	X	X	X	X	X
TH 5,5.15	X	X	X	X	X	✓	✓	✓	✓
TH 5,5.19	X	X	X	X	X	✓	✓	✓	✓
TH 5,5.24	X	X	X	X	X	✓	✓	✓	✓
TH 6.20	X	X	X	X	X	✓	✓	✓	✓
TH 7.10	X	X	X	X	X	✓	✓	✓	✓
HTH 10.10	X	X	X	X	✓	✓	X	X	✓
HTH 12.10	X	X	X	X	✓	✓	X	X	✓
HTH 16.10	✓	✓	X	✓	X	X	X	X	X
HTH 20.10	✓	✓	X	✓	X	X	X	X	X
HTH 25.11	✓	✓	X	✓	X	X	X	X	X
HTH 27.11	✓	✓	X	✓	X	X	X	X	X
HTH 30.12	✓	✓	X	✓	X	X	X	X	X
HTH 35.12	✓	✓	X	✓	X	X	X	X	X
HTH 50.14	X	X	X	X	X	X	X	X	X

	ATT-07-013	ATT-07-014	ATT-07-015	ATT-07-016	ATT-07-017	ATT-07-018	ATT-07-019	ATT-07-020
RTH 5.18	X	X	X	X	X	X	✓	✓
RTH 5.21	X	X	X	X	X	X	✓	✓
RTH 5.23	X	X	X	X	X	X	✓	✓
RTH 5.25	X	X	X	X	X	X	✓	✓
RTH 6.22	X	X	X	X	X	X	✓	✓
RTH 6.22 EC/TC	X	X	X	X	X	X	✓	✓
RTH 6.26	X	X	X	X	X	X	✓	✓
RTH 6.26 EC/TC	X	X	X	X	X	X	✓	✓
RTH 6.31	X	X	X	X	X	X	✓	✓
RTH 6.31 EC/TC	X	X	X	X	X	X	✓	✓
RTH 6.51	X	X	X	X	X	X	✓	✓
RTH 8.27	X	X	X	X	X	X	✓	✓
RTH 8.35	X	X	X	X	X	X	✓	✓
RTH 8.39	X	X	X	X	X	X	✓	✓
RTH 8.46	X	X	X	X	X	X	✓	✓
RTH 10.37	X	X	X	X	X	X	✓	✓
RTH 13.26	X	X	X	X	X	X	✓	✓
TH 3.6	X	X	X	X	X	X	X	X
TH 4,5.15	✓	✓	✓	✓	✓	✓	X	X
TH 4,5.19	✓	✓	✓	✓	✓	✓	X	X
TH 5.8	X	X	✓	X	X	X	X	X
TH 5,5.15	✓	✓	✓	✓	✓	✓	X	X
TH 5,5.19	✓	✓	✓	✓	✓	✓	X	X
TH 5,5.24	✓	✓	✓	✓	✓	✓	X	X
TH 6.20	✓	✓	✓	✓	✓	✓	X	X
TH 7.10	✓	✓	✓	✓	✓	✓	X	X
HTH 10.10	X	X	X	X	X	X	✓	✓
HTH 12.10	X	X	X	X	X	X	✓	✓
HTH 16.10	X	X	X	X	X	X	X	X
HTH 20.10	X	X	X	X	X	X	X	X
HTH 25.11	X	X	X	X	X	X	X	X
HTH 27.11	X	X	X	X	X	X	X	X
HTH 30.12	X	X	X	X	X	X	X	X
HTH 35.12	X	X	X	X	X	X	X	X
HTH 50.14	X	X	X	X	X	X	X	X

✓: yes X: no

SPECIAL EQUIPMENT



This category covers our attachment range for specialised applications. From removing large trees to cleaning roads with snow ploughs or installing glass panels high up on tall buildings - Magni always has the best solution for specialised requirements.

Check the compatibility and capacity of each attachment with your dealer.



TREE CUTTER BOOM WITH CLAMP 3,300 LB

ATT - 08 - 005

Tree cutter boom with clamp designed for felling and handling tree branches. The unit offers fast, efficient and safe operation for tree maintenance and branch removal. The combination of boom, tilting clamp and chainsaw enables smaller sections of the tree to be removed from any direction, facilitating immediate clearing. On suitably equipped machines, thanks to the availability of kit solutions, it is a plug-and-play solution. OPT-05-001 pre-arrangement kit and OPT-05-005 boom protection kit for tree cutters and dusty environments required

CHECK FOR ANY PREARRANGEMENT REQUIREMENTS

JGS-GMT050 TTC

			
3,300 lb	7'8"	4'	✓





TREE CUTTER

ATT - 08 - 001

Clamp with chainsaw for felling and removing trees which are dangerous or in challenging locations, like urban and residential areas, along roadsides and railway lines. On suitably equipped machines, thanks to the availability of pre-arrangement and boom protection kits, it is a plug-and-play solution. The attachment features a saw unit with spring suspension which prevents the blade flexing when force is applied. Thanks to the Power Tiltator, the clamp can rotate through 360°, thus enabling a secure grip on the branch or tree even in the most challenging positions. OPT-05-001 e OPT-05-005 pre-arrangement kit required.

CHECK FOR ANY PREARRANGEMENT REQUIREMENTS

		
4'2"	360°	✓



CONCRETE BUCKET 0.78 YD³

ATT - 08 - 010

Concrete bucket with 0.78 yd³ capacity and hydraulically operated outlet

**CHECK FOR ANY PREARRANGEMENT
REQUIREMENTS**

BB 600

0.78 yd ³	4'8"	6'7"	3'10"	3'8"	X



MIXER BUCKET 0.92 YD³

ATT - 08 - 014

Mixer bucket with a capacity of 0.92 yd³, complete with HB400 wear-resistant steel bottom and mixer blades, fixed curved protection grille with bag breaker, solenoid valve, hydraulic lines, electric control kit, hydraulically operated outlet and outlet pipe. OPT-02-022 required.

**CHECK FOR ANY PREARRANGEMENT
REQUIREMENTS**

MB 700 SL

CLASS	WIDTH	CAPACITY	TRANSMISSION	UNLADEN WEIGHT	
3	6'10"	0.92 yd ³	chain	1,685 lb	✓

PAPER CLAMP 7,050 LB

ATT - 08 - 018

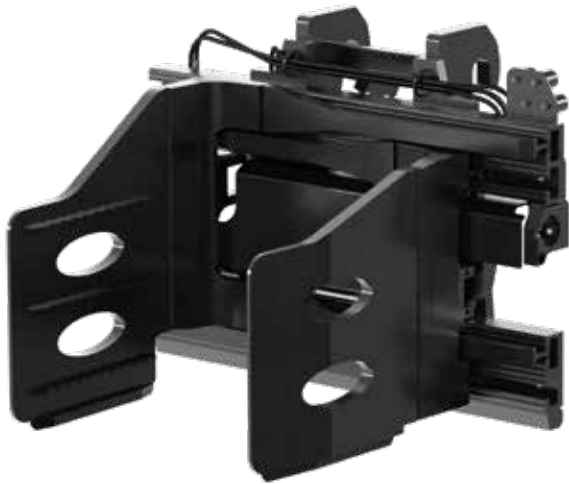

Clamp designed for recycling, heavy-duty logistics and paper/cellulose supply chain applications. Designed to assure an unobstructed view of the chassis from any angle. The optimised boom profile provides outstanding performance without compromising the strength of the assembly. The chassis is steel, the boom bars in extruded steel alloy, and the boom bases are in cast iron, for excellent durability and reliability. Built-in hydraulic flow diverters and a two-way pressure regulator valve assure fast, synchronised operation of the booms.

LOAD CAPACITY AT CENTRE OF GRAVITY	CHASSIS WIDTH	CHASSIS HEIGHT	INTERNAL/INTERNAL OPENING	CLAMP JAWS	JAW THICKNESS	MINIMUM CLAMP JAW OPENING	HYDRAULIC FUNCTIONS
7,050 lb @1'8"	4'1"	2'5"	2'3" - 7'6"	1'10"	Fixed 3.1"	2'8"	2

ET-HOVER-UNIVAC VACUUM LIFTING ATTACHMENT

ATT - 08 - 007

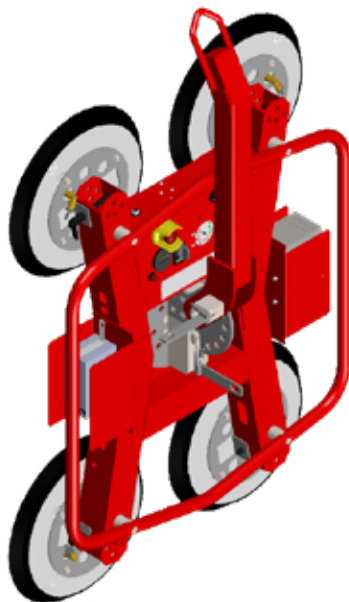

The eT-Hover-univac vacuum lifting attachment is designed to safely handle glass, ceramic and metal panels. It can lift loads of up to 1,550 lb in the horizontal and vertical orientations. Thanks to its modular structure, the lifting device can be adjusted to fit the size of the part. Four additional suction cups are included for handling even larger panels, up to the maximum load of 1,550 lb. But even in its basic configuration with 4 suction cups, it can lift up to 790 lb in the vertical orientation and 1,100 lb in the horizontal orientation. The attachment comes with handy compact remote control for the vacuum function. Winch for attachment handling required (not included).

CHECK FOR ANY PREARRANGEMENT REQUIREMENTS

ET-HOVER-UNIVAC					
MAXIMUM LOAD CAPACITY	HORIZONTAL LOAD CAPACITY	VERTICAL LOAD CAPACITY	NO. SUCTION CUPS	VACUUM SYSTEM	
1,550 lb (with 8 suction cups)	1,100 lb	790 lb	4+4 (BLSP 400 RL)	Diaphragm pump; 74,16 ft³/h, 12 V DC	X



ET-LITOCRAN700 TELESCOPIC VACUUM HANDLER

ATT - 08 - 021

The attachment combines a 3D head with a telescopic boom which extends up to 10'6" from the fixed or rotating telescopic handler's boom head. The tip of the attachment's boom is equipped with the vacuum head. A remote control enables the unit to be controlled precisely in any direction. Ideal for the safe handling of glass, ceramic and metal panels. It can lift loads of up to 1,550 lb in the horizontal and vertical orientations. The panels can be tilted 90° and rotated through 360° by hand. The four additional suction cups included in the kit enable larger panels to be handled by adapting the handler to the size of the panel, up to the maximum load of 1,550 lb. But even in its basic configuration with 4 suction cups, it can lift up to 1,100 lb in the vertical orientation and 790 lb in the horizontal orientation. The attachment charges in about 4 hours, and a full charge provides 8 hours of operation. A handy compact remote control for the vacuum function is included.

CHECK FOR ANY PREARRANGEMENT REQUIREMENTS

ET-LITOCRAN700

MAXIMUM LOAD CAPACITY	HORIZONTAL LOAD CAPACITY	VERTICAL LOAD CAPACITY	ROTATION	NO. SUCTION CUPS	VACUUM SYSTEM	POWER SUPPLY	BATTERY LIFE	CHARGING TIME	M RFID
1,550 lb (with 8 suction cups)	1,100 lb	790 lb	360° continuous, by hand	4+4 (BLSP 400 RL)	Diaphragm pump; 74,16 ft³/h, 12 V DC	12 V / 4 A	8 hours	3 - 4 hours	✓



SUSPENSION CYLINDER TOOL

ATT - 08 - 002

The attachment is specially designed for safely removing dump truck suspensions and front gearboxes. ATT-08-004 required.

CHECK FOR ANY PREARRANGEMENT REQUIREMENTS

SCT

							M RFID
Hub + Suspension: 19,800 lb Suspension only: 15,400 lb	9'9"	60°	360°	360°	+/- 1'	Without adapter: 1'2" - 1'9" With adapter: 10" - 1'4"	✓



WHEEL HUB TOOL

ATT - 08 - 003

Attachment for safely removing dump truck wheel hubs. It can also be used for other quarry and construction vehicles. ATT-08-004 required.

CHECK FOR ANY PREARRANGEMENT REQUIREMENTS

RWTH

<p>48,500 lb</p>	<p>2'9" - 4'4"</p>	<p>+/- 30°</p>	<p>✓</p>



MULTITOOL - HANDLER FOR MULTIPLE ATTACHMENTS

ATT - 08 - 004

Support for the following attachments:

- ATT-06-010
- ATT-08-002
- ATT-08-003





MTM



CONVEYOR BELT MAINTENANCE UNIT, UP TO 55,100 LB

ATT - 08 - 008

Attachment for changing conveyor belts. The attachment has two stabiliser feet for use when removing/installing the belts, and a hydraulic extension for gripping/releasing the drive wheel drum. It can handle up to 13'1" diameter and 7'4" long drums with the belt wound onto them, with a load capacity of up to 55,100 lb

CBR				
				
55,100 lb	3'11" - 9'4"	14'7" - 22'8"	360°	✓



SNOW PLOUGH BLADE

ATT - 08 - 009

Snow plough blade with a steel frame and quick-coupling counterplate (DIN 76060/A compliant), or alternatively a three-point bracket for three-point front hitches as typically found on agricultural machinery. The front edge of the blade is constructed in two all-steel sections. The scraper blade is made of six independent wear-resistant steel sectors. The unit features an impact mitigation system with adjustable steel springs on each individual sector of the scraper blade. These flex backwards (against the direction of travel) in the event of a collision. It also has an overpressure valve to dampen side impacts, with R2 hydraulic pipe and unified quick fittings and couplings. The LTL blade can be configured as a wedge, as a single tilted blade facing left or right, or as an inverse wedge (spoon).

ATTACHMENT WEIGHT	TIP HEIGHT	BLADE END HEIGHT	WORKING WIDTH	MAX. WIDTH FOR TRANSPORT ON THE ROAD	
2,000 lb	3'2"	3'9"	11'5"	13'1"	✓

STEEL COIL HANDLER 66,100 LB (STRUT) WITH POSITIONER



ATT - 08 - 012

Attachment for handling large steel coils in heavy industry applications, up to 66,100 lb. Equipped with a levelling indicator and +/- 1' extra side shift to facilitate handling.

SCT 30T

			
66,100 lb	6'7"	+/- 1	✓

STEEL COIL HANDLER 48,500 LB (CLAMP)



ATT - 08 - 013

Attachment for handling large steel coils in heavy industry applications, for coils from 3'11" to 5'3" diameter. Pivot tilt +/- 90° and side shift +/- 1'

CH 22T

					
48,500 lb	MAX 5'3"	MIN 3'11"	+/- 90°	+/- 1'	✓



HANDLING AND DEMOLITION CLAMP

ATT - 08 - 011

Loader bucket with reinforced construction for safe, stable loading. 360° rotation and 5'6" opening. OPT-02-022 required.

CHECK FOR ANY PREARRANGEMENT REQUIREMENTS

BM 120

			
<p>4,400 lb</p>	<p>5'6"</p>	<p>360°</p>	<p>✓</p>

COMPATIBILITY

	ATT-08-001	ATT-08-002	ATT-08-003	ATT-08-004	ATT-08-005	ATT-08-007	ATT-08-008	ATT-08-009
RTH 5.18	✓	✗	✗	✗	✓	✓	✗	✗
RTH 5.21	✓	✗	✗	✗	✓	✓	✗	✗
RTH 5.23	✓	✗	✗	✗	✓	✓	✗	✗
RTH 5.25	✓	✗	✗	✗	✓	✓	✗	✗
RTH 6.22	✓	✗	✗	✗	✓	✓	✗	✗
RTH 6.22 EC/TC	✓	✗	✗	✗	✓	✓	✗	✗
RTH 6.26	✓	✗	✗	✗	✓	✓	✗	✗
RTH 6.26 EC/TC	✓	✗	✗	✗	✓	✓	✗	✗
RTH 6.31	✓	✗	✗	✗	✓	✓	✗	✗
RTH 6.31 EC/TC	✓	✗	✗	✗	✓	✓	✗	✗
RTH 6.51	✓	✗	✗	✗	✓	✓	✗	✗
RTH 8.27	✓	✗	✗	✗	✓	✓	✗	✗
RTH 8.35	✓	✗	✗	✗	✓	✓	✗	✗
RTH 8.39	✓	✗	✗	✗	✓	✓	✗	✗
RTH 8.46	✓	✗	✗	✗	✓	✓	✗	✗
RTH 10.37	✓	✗	✗	✗	✓	✓	✗	✗
RTH 13.26	✓	✗	✗	✗	✓	✓	✗	✗
<hr/>								
TH 3.6	✗	✗	✗	✗	✗	✗	✗	✗
TH 4,5.15	✗	✗	✗	✗	✗	✓	✗	✗
TH 4,5.19	✗	✗	✗	✗	✗	✓	✗	✗
TH 5.8	✗	✗	✗	✗	✗	✓	✗	✗
TH 5,5.15	✗	✗	✗	✗	✗	✓	✗	✗
TH 5,5.19	✗	✗	✗	✗	✗	✓	✗	✗
TH 5,5.24	✗	✗	✗	✗	✗	✓	✗	✗
TH 6.20	✗	✗	✗	✗	✗	✓	✗	✗
TH 7.10	✗	✗	✗	✗	✗	✓	✗	✗
<hr/>								
HTH 10.10	✗	✗	✗	✗	✗	✓	✗	✗
HTH 12.10	✗	✗	✗	✗	✗	✓	✗	✗
HTH 16.10	✗	✓	✓	✓	✗	✗	✓	✓
HTH 20.10	✗	✓	✓	✓	✗	✗	✓	✓
HTH 25.11	✗	✓	✓	✓	✗	✗	✓	✓
HTH 27.11	✗	✓	✓	✓	✗	✗	✓	✓
HTH 30.12	✗	✓	✓	✓	✗	✗	✓	✓
HTH 35.12	✗	✓	✓	✓	✗	✗	✓	✓
HTH 50.14	✗	✗	✗	✗	✗	✗	✗	✗

	ATT-08-010	ATT-08-011	ATT-08-012	ATT-08-013	ATT-08-014	ATT-08-018	ATT-08-021
RTH 5.18	✓	✓	✗	✗	✓	✗	✓
RTH 5.21	✓	✓	✗	✗	✓	✗	✓
RTH 5.23	✓	✓	✗	✗	✓	✗	✓
RTH 5.25	✓	✓	✗	✗	✓	✗	✓
RTH 6.22	✓	✓	✗	✗	✓	✗	✓
RTH 6.22 EC/TC	✓	✓	✗	✗	✓	✗	✓
RTH 6.26	✓	✓	✗	✗	✓	✗	✓
RTH 6.26 EC/TC	✓	✓	✗	✗	✓	✗	✓
RTH 6.31	✓	✓	✗	✗	✓	✗	✓
RTH 6.31 EC/TC	✓	✓	✗	✗	✓	✗	✓
RTH 6.51	✓	✓	✗	✗	✓	✗	✓
RTH 8.27	✓	✓	✗	✗	✓	✗	✓
RTH 8.35	✓	✓	✗	✗	✓	✗	✓
RTH 8.39	✓	✓	✗	✗	✓	✗	✓
RTH 8.46	✓	✓	✗	✗	✓	✗	✓
RTH 10.37	✓	✓	✗	✗	✓	✗	✓
RTH 13.26	✓	✓	✗	✗	✓	✗	✓
TH 3.6	✗	✗	✗	✗	✗	✗	✗
TH 4,5.15	✓	✗	✗	✗	✓	✓	✓
TH 4,5.19	✓	✗	✗	✗	✓	✓	✓
TH 5.8	✓	✗	✗	✗	✓	✓	✓
TH 5,5.15	✓	✗	✗	✗	✓	✓	✓
TH 5,5.19	✓	✗	✗	✗	✓	✓	✓
TH 5,5.24	✓	✗	✗	✗	✓	✓	✓
TH 6.20	✓	✗	✗	✗	✓	✓	✓
TH 7.10	✓	✗	✗	✗	✓	✓	✓
HTH 10.10	✓	✓	✗	✗	✓	✓	✗
HTH 12.10	✓	✓	✗	✗	✓	✓	✗
HTH 16.10	✗	✗	✓	✓	✗	✗	✗
HTH 20.10	✗	✗	✓	✓	✗	✗	✗
HTH 25.11	✗	✗	✓	✓	✗	✗	✗
HTH 27.11	✗	✗	✓	✓	✗	✗	✗
HTH 30.12	✗	✗	✓	✓	✗	✗	✗
HTH 35.12	✗	✗	✓	✓	✗	✗	✗
HTH 50.14	✗	✗	✗	✗	✗	✗	✗

✓: yes ✗: no

SECTION

LIST OF ATTACHMENTS

DESCRIPTION	CODE	PRODUCT	SECTION
PLATFORMS			
Extendable rotating platform, 2200 lb	ATT-01-016	REP 10.2-4,7	1-9
Extendable rotating platform, 2200 lb, for asbestos mitigation	ATT-01-018	RPRAB 10-3,5	1-12
Extendable rotating platform, 1,100 lb, for roofing applications	ATT-01-020	RRP 10.2,5-3,5	1-13
Extendable rotating platform, 1,100 lb - 14'9"	ATT-01-007	REP 2-4,5	1-8
Extendable rotating platform, 1,100 lb - 18'0.5"	ATT-01-009	REP 2-5.5	1-8
Extendable rotating platform, 1,100 lb - 21'4"	ATT-01-011	REP 2-6.5	1-9
Extendable rotating platform, 1,100 lb, with 1,300 lb capacity winch	ATT-01-026	REP 5.2-4,5 WO,6	1-11
Mining platform, 1,000 lb	ATT-01-027	CP 1.8	1-11
Platform, 550 lb	ATT-01-001	P 1,4	1-6
Platform, 550 lb	ATT-01-002	PS 1,4	1-7
Rotating platform for working in tunnels, 1,100 lb	ATT-01-013	CRP 5	1-12
Rotating platform, 550 lb	ATT-01-003	RP 1,4	1-6
Rotating platform, 1,100 lb	ATT-01-005	RP 2,2	1-7
Telescopic platform, 440 lb	ATT-01-022	TP 2.10	1-10
Telescopic platform, 1,000 lb	ATT-01-004	TP 4,5.10	1-11
Telescopic platform, positive/negative, 550 lb	ATT-01-024	TP O-U-R	1-10

DESCRIPTION	CODE	PRODUCT	SECTION
WINCHES			
Double pull winch 28,600 lb	ATT-02-018	W 13	2-7
Double pull winch 35,300 lb	ATT-02-008	W 16	2-6
Double pull winch 6,000 lb	ATT-02-001	W 2,7	2-2
Double pull winch 7,700 lb	ATT-02-002	W 3,5	2-2
Double pull winch 11,000 lb	ATT-02-019	W 5	2-3
Double pull winch 13,200 lb	ATT-02-004	W 6	2-4
Double pull winch 17,600 lb	ATT-02-006	W 8	2-5
Rear boom winch, single pull 6,600 lb / double pull 13,200 lb - for RTH 6.22, for road use	ATT-02-022	WB 6	2-7
Rear boom winch, single pull 6,600 lb / double pull 13,200 lb - for RTH 6.26, for road use	ATT-02-012	WB 6	2-8
Rear boom winch, single pull 6,600 lb / double pull 13,200 lb - for RTH 6.31, for road use	ATT-02-013	WB 6	2-8
Rear boom winch, single pull 9,050 lb / double pull 17,600 lb - for RTH 8.27, for road use	ATT-02-005	WB 8	2-9
Single pull winch 3,850 lb / double pull winch 7,700 lb	ATT-02-009	W 3,5 - 1,75	2-3
Single pull winch 6,600 lb / double pull 13,200 lb	ATT-02-010	W 3 - 6	2-4
Single pull winch 8,800 lb / double pull winch 17,600 lb	ATT-02-023	W 4 - 8	2-5
Single pull winch 11,000 lb / double pull winch 22,000 lb	ATT-02-021	W 5 - 10	2-6

SECTION

LIST OF ATTACHMENTS

DESCRIPTION	CODE	PRODUCT	SECTION
FORK CARRIAGES			
FEM fork carriage 5,500 lb, side tipping - for emptying bins	ATT-03-054	RFCFS 2,5 FIX	3-17
FEM fork carriage 6,600 lb	ATT-03-034	FCFS 3T FIX	3-2
FEM fork carriage 13,200 lb	ATT-03-010	FCF 6T 1,3	3-10
FEM fork carriage 17,600 lb	ATT-03-037	FCF 8T SH 1,3	3-13
FEM fork carriage for TH	ATT-03-043	FCF 1,3 FIX	3-5
FEM fork carriage with positioner	ATT-03-045	FCP FIX	3-6
FEM fork carriage with side shift	ATT-03-044	FCTF	3-6
FEM fork carriage with side shift and positioner	ATT-03-046	FCPT FIX R	3-7
FEM rotating fork carriage	ATT-03-041	RFC 5	3-15
FEM rotating fork carriage with tilt	ATT-03-002	RFCT 5	3-15
FEM standard fork carriage, 11,000 lb	ATT-03-003	FCF 5T 1,3	3-9
Floating fork carriage 22,000 lb	ATT-03-047	FC 10T	3-14
Floating fork carriage 22,000 lb	ATT-03-018	F 10T	3-17
Floating fork carriage 22,000 lb (wide) with 8'2" long forks and positioner	ATT-03-020	FCP 10T 2,5 C	3-18
Floating fork carriage 22,000 lb (wide) with positioner and side shift	ATT-03-036	FCPT 10T 1,5	3-19
Floating fork carriage 22,000 lb with positioner	ATT-03-019	FCP 10T	3-18
Floating fork carriage 26,890 lb	ATT-03-013	FC 12,2T	3-19
Floating fork carriage 26,890 lb with 8'2" long forks	ATT-03-050	FC 12,2T 2,5	3-20
Floating fork carriage 26,890 lb with 8'2" long forks and positioner	ATT-03-052	FCP 12,2T 2,5	3-21
Floating fork carriage 26,890 lb with forks for containers and positioner	ATT-03-053	FCP 12,2T 2,5 C	3-21
Floating fork carriage 26,890 lb with positioner	ATT-03-051	FCP 12,2T	3-20
Floating fork carriage 28,600 lb with positioner	ATT-03-021	FCP 13T	3-14
Floating fork carriage 35,300 lb	ATT-03-022	F 16T	3-22
Floating fork carriage 35,300 lb (wide) with 7'10" long forks and positioner	ATT-03-025	FCPT 16T C	3-23
Floating fork carriage 35,300 lb with 7'10" long forks, with positioner and side shift	ATT-03-024	FCPT 16 2,4	3-23
Floating fork carriage 35,600 lb with positioner	ATT-03-023	FCP 16T	3-22
Floating fork carriage 44,100 lb with positioner	ATT-03-026	FCP 20T	3-24

DESCRIPTION	CODE	PRODUCT	SECTION
FORK CARRIAGES			
Floating fork carriage 52,900 lb (wide) with 7'10" long forks and positioner	ATT-03-028	FCP 24T 2,4	3-25
Floating fork carriage 52,900 lb with positioner	ATT-03-027	FCP 24T	3-24
Floating fork carriage 59,500 lb with positioner	ATT-03-029	FCP 27T	3-25
Floating fork carriage 6,600 lb	ATT-03-016	FCS 3T FIX	3-2
Floating fork carriage 66,100 lb (wide) with positioner and side shift	ATT-03-031	FCPT 30T 2,4 R	3-27
Floating fork carriage 66,100 lb with positioner	ATT-03-030	FCP 30T	3-26
Floating fork carriage 66,100 lb, adjustable width, with positioner	ATT-03-032	FCEP 30T 2,4 R	3-26
Floating fork carriage 77,100 lb with positioner	ATT-03-033	FCP 35T	3-27
Floating fork carriage 10,000 lb	ATT-03-042	FC 4,5T FIX	3-3
Floating fork carriage 10,000 lb	ATT-03-039	FC 5T FIX	3-3
Floating fork carriage 10,000 lb	ATT-03-001	FC 5T	3-8
Floating fork carriage 12,100 lb	ATT-03-040	FC 5,5T FIX	3-4
Floating fork carriage 13,200 lb	ATT-03-008	FC 6T	3-10
Floating fork carriage 13,200 lb	ATT-03-004	FC 6T FIX L S	3-4
Floating fork carriage 13,200 lb	ATT-03-006	FC 6T L	3-9
Floating fork carriage 13,200 lb (wide) with 4'11" long forks	ATT-03-009	FC 6T 6x5 FT	3-11
Floating fork carriage 13,200 lb (wide) with 5'11" long forks	ATT-03-014	FC 6T 72x72 FIX	3-11
Floating fork carriage 15,400 lb	ATT-03-011	FC 7T FIX S	3-5
Floating fork carriage 17,600 lb	ATT-03-015	FC 8T L	3-12
Floating fork carriage 17,600 lb (wide) with 5'11" long forks	ATT-03-017	FC 8T 72x72	3-13
Floating fork carriage 17,600 for RHT 8.46	ATT-03-007	FC 8T 46 L	3-12
Load protection grille for FEM fork carriages	ATT-03-005	PCF	3-16
Load protection grille for floating fork carriages	ATT-03-038	PC	3-16
Wide fork carriage with long forks (72x60")	ATT-03-049	FC 6x5 FIX	3-8
Wide fork carriage with long forks (72x72")	ATT-03-048	FC 72x72 FIX	3-7

SECTION

LIST OF ATTACHMENTS

DESCRIPTION	CODE	PRODUCT	SECTION
LATTICE BOOMS WITH/WITHOUT WINCH			
Boom with 3 hooks, 44,100 lb - 33,100 lb - 22,100 lb	ATT-04-008	J 20 S-3	4-9
Box-shaped boom with hook 4,400 lb	ATT-04-013	J 2000	4-5
Box-shaped boom with hook 8,800 lb	ATT-04-024	J 4000	4-6
Box-shaped boom with hook 17,600 lb	ATT-04-026	J 8000	4-9
Box-shaped boom with two hooks 4,400 lb - 15,400 lb	ATT-04-027	J 2000 / 7000	4-6
Hydraulic telescopic boom with hook 3,300 lb / 5,500 lb	ATT-04-021	JT 2500	4-7
Lattice boom with double pull winch 4,400 lb	ATT-04-015	JW 2000	4-3
Lattice boom with hook 1,300 lb	ATT-04-001	J 600	4-5
Lattice boom with single pull winch 3,300 lb	ATT-04-011	JW 1500	4-3
Lattice boom with single pull winch 6,000 lb	ATT-04-017	JW 2700	4-4
Lattice boom with single pull winch 6,600 lb	ATT-04-019	JW 3000	4-4
Lattice boom with single pull winch 1,750 lb	ATT-04-005	JW 800	4-2
Lattice boom with single pull winch 2,000 lb	ATT-04-028	JW 900	4-2
Lattice boom with winch, single pull 2,650 lb / double pull 6,600	ATT-04-009	JW 1200/3000	4-8
Lattice boom with winch, single pull 1,750 lb / double pull 3,300 lb	ATT-04-007	JW 800/1500	4-7
Swan-neck boom with hook 6,600 lb	ATT-04-023	JCC 3000	4-8
HOOKS			
Hook 22,000 lb	ATT-05-005	H 10	5-4
Hook 28,600 lb	ATT-05-013	H 13	5-5
Hook 35,300 lb	ATT-05-007	H 16S	5-5
Hook 44,100 lb	ATT-05-008	H 20S	5-6
Hook 6,600 lb	ATT-05-004	HS 3	5-2
Hook 66,100 lb	ATT-05-009	H 30S	5-6
Hook 88,100 lb (narrow)	ATT-05-011	H 40S	5-7
Hook 11,000 lb	ATT-05-014	H 5	5-2
Hook 110,200 lb	ATT-05-012	H 50	5-7
Hook 13,200 lb	ATT-05-001	H 6	5-3
Hook 15,400 lb	ATT-05-002	H 7	5-3
Hook 17,600 lb	ATT-05-003	H 8	5-4

DESCRIPTION	CODE	PRODUCT	SECTION
CLAMPS			
3D-Film handler 5,500 lb	ATT-06-002	3DF 2,5	6-2
Cylinder handler 24,250 lb	ATT-06-010	CC	6-6
Cylinder handler 10,000 lb	ATT-06-011	CC 4.5	6-4
Cylinder handler 10,000 lb	ATT-06-012	CC 4.5	6-6
Pipes handler 2,200 lb	ATT-06-009	PC 1000	6-4
Ribs clamp 8,800 lb	ATT-06-001	RC 4T	6-2
Tyre clamp 7,700 lb - 55"	ATT-06-004	TC 3,5	6-7
Tyre handler 35,300 lb - 63"	ATT-06-007	TC 16.63 CP	6-5
Tyre handler 5,500 lb - 25"	ATT-06-003	TC 2,5.25	6-3
Tyre handler 8,400 lb - 49"	ATT-06-005	TC 3,8.49	6-3
Tyre handler 17,600 lb - 63"	ATT-06-006	TC 08.63	6-5
BUCKETS			
Aggregate container 2.62 yd ³	ATT-07-007	BIM 2000	7-8
Bucket 2.62 yd ³	ATT-07-003	CB 2000	7-2
Bucket 3.92 yd ³	ATT-07-004	CB 3000	7-2
Bucket 7.72 yd ³ (4x1)	ATT-07-006	4X1 5900	7-9
Bucket 1.11 yd ³ (4x1)	ATT-07-009	4X1 850L	7-9
Bucket with bolt-on cutting edge 1.31 yd ³	ATT-07-015	CB 1000 DL	7-3
Bucket with bolt-on cutting edge 1.96 yd ³	ATT-07-016	CB 1500 DL	7-3
Bucket with bolt-on cutting edge 2.62 yd ³	ATT-07-018	CB 2000 DL	7-4
Bucket with welded cutting edge 1.31 yd ³	ATT-07-013	CB 1000 SL	7-6
Bucket with welded cutting edge 1.96 yd ³	ATT-07-014	CB 1500 SL	7-6
Bucket with welded cutting edge 2.62 yd ³	ATT-07-017	CB 2000 SL	7-7
Bucket with welded cutting edge 1.05 yd ³	ATT-07-005	CB 800 SL	7-10
Reinforced bucket with bolt-on cutting edge 1.96 yd ³	ATT-07-010	CB 1500	7-4
Reinforced bucket with bolt-on cutting edge, 2.62 yd ³	ATT-07-011	CB 2000	7-5
Reinforced bucket with bolt-on cutting edge, 3.27 yd ³	ATT-07-012	CB 2500	7-5
Reinforced bucket with welded cutting edge 1.31 yd ³	ATT-07-019	CB 1000	7-7
Reinforced bucket with welded cutting edge 1.96 yd ³	ATT-07-020	CB 1500	7-8

SECTION

LIST OF ATTACHMENTS

DESCRIPTION	CODE	PRODUCT	SECTION
SPECIAL EQUIPMENT			
Concrete bucket 0.78 yd ³	ATT-08-010	BB 600	8-3
Conveyor belt maintenance unit, 55,100 lb	ATT-08-008	CBR	8-7
eT-Hover-univac vacuum lifting attachment	ATT-08-007	ET-HOOVER-UNIVAC	8-4
eT-Litocran700 telescopic vacuum handler	ATT-08-021	ET-LITOCRAN700	8-5
Handling and demolition clamp	ATT-08-011	BM 120	8-9
Mixer bucket 0.92 yd ³	ATT-08-014	MB 700 SL	8-3
Multitool - Handler for multiple attachments	ATT-08-004	MTM	8-6
Paper clamp 7,050 lb	ATT-08-018	-	8-4
Snow plough blade	ATT-08-009	-	8-7
Steel coil handler 48,500 lb (clamp)	ATT-08-013	CH 22T	8-8
Steel coil handler 66,100 lb (strut) with positioner	ATT-08-012	SCT 30T	8-8
Suspension cylinder tool	ATT-08-002	SCT	8-5
Tree cutter	ATT-08-001	-	8-2
Tree cutter boom with clamp 3,300 lb	ATT-08-005	JGS-GMT050 TTC	8-2
Wheel hub tool	ATT-08-003	RWTH	8-6





magnith.com

#LIFTDIFFERENT