

**TH**

**5,5.15 P**



CONSTRUCTION



LOGISTICS



EVENTS AND  
FILM



TH  
5,5.15 P



**CAB**

Best-in-class  
safety and visibility



**PERFORMANCE**

Unrivalled lifting  
performance



**LOAD LIVE DIAGRAM**

Two real-time dynamic  
load charts

# TH 5,5.15 P

## DIMENSIONS (mm)

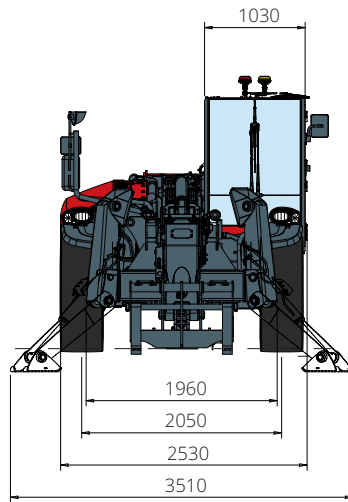

**FRONT**  
view

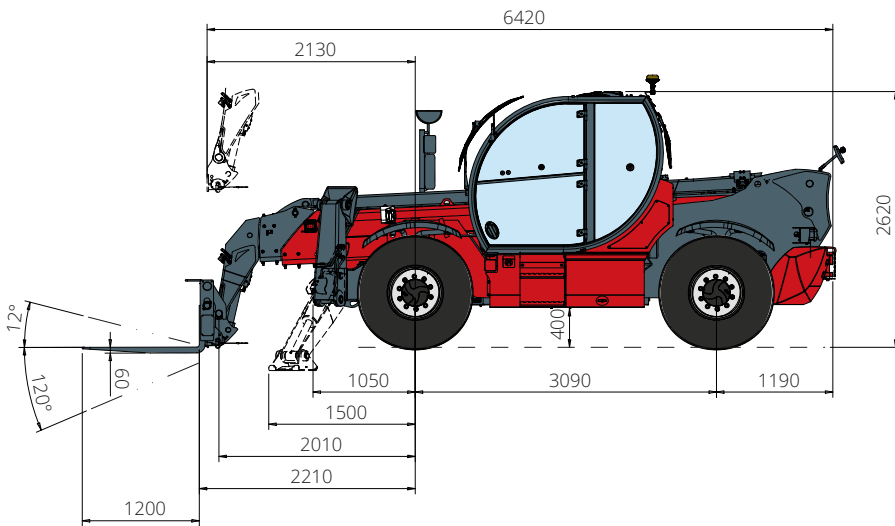

**SIDE**  
view

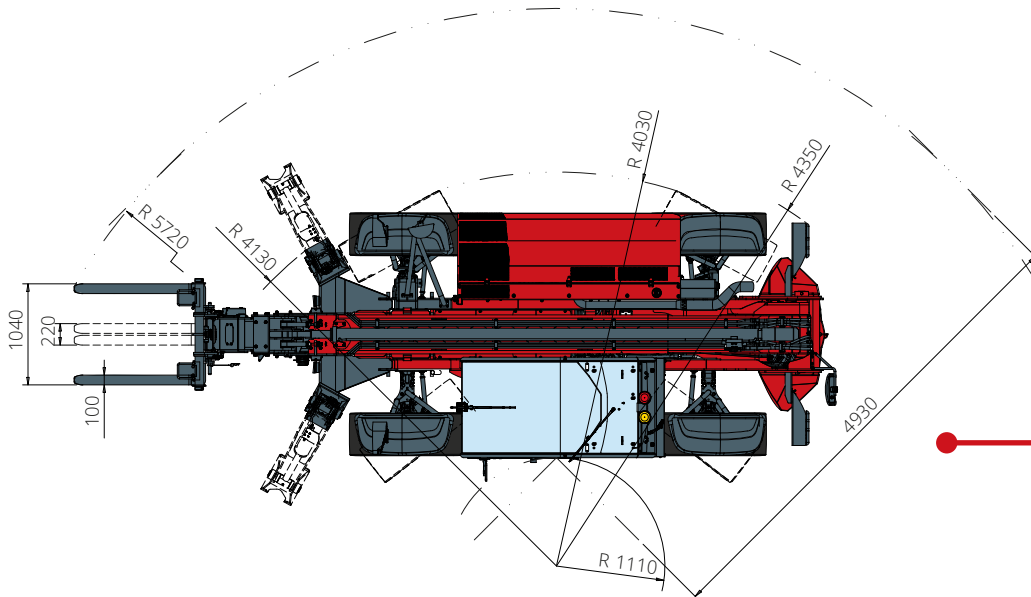

**TOP**  
view

Load chart with  
**FULLY EXTENDED STABILISERS**

ATT-03-040

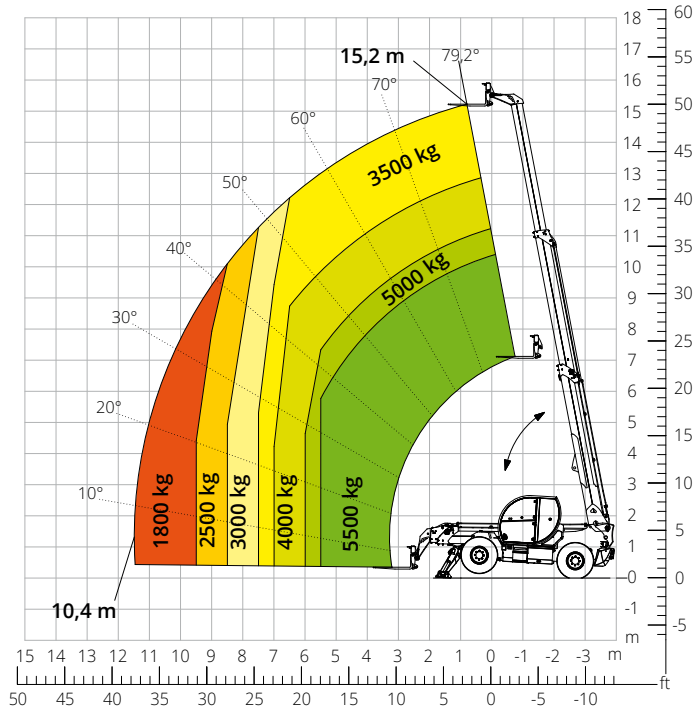

Load chart  
**FRONT ATTACHMENT ON TYRES**

ATT-03-040

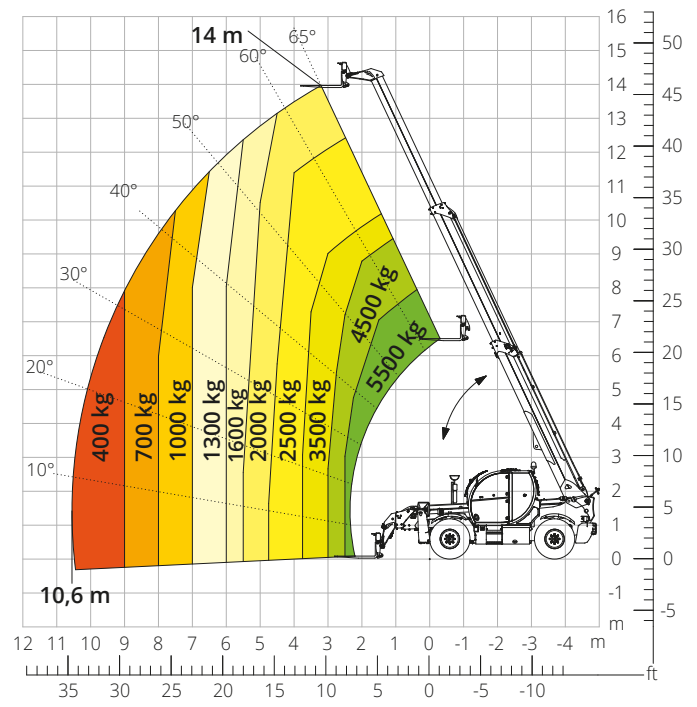

Load chart with  
**WINCH 5,000 kg**

ATT-02-019

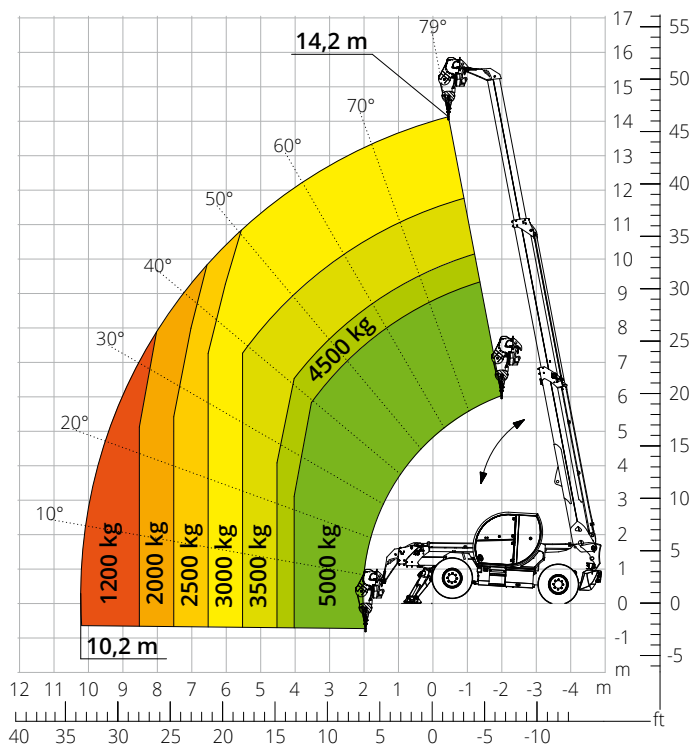

Load chart with  
**WINCH 6,000 kg**

ATT-02-004

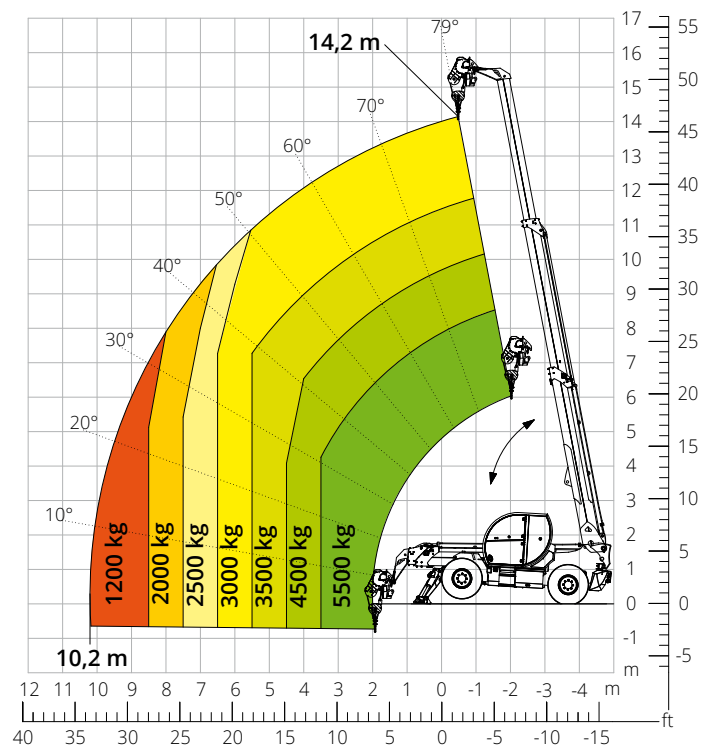

Load chart with  
**JIB WITH WINCH 2,000 kg**

ATT-04-015

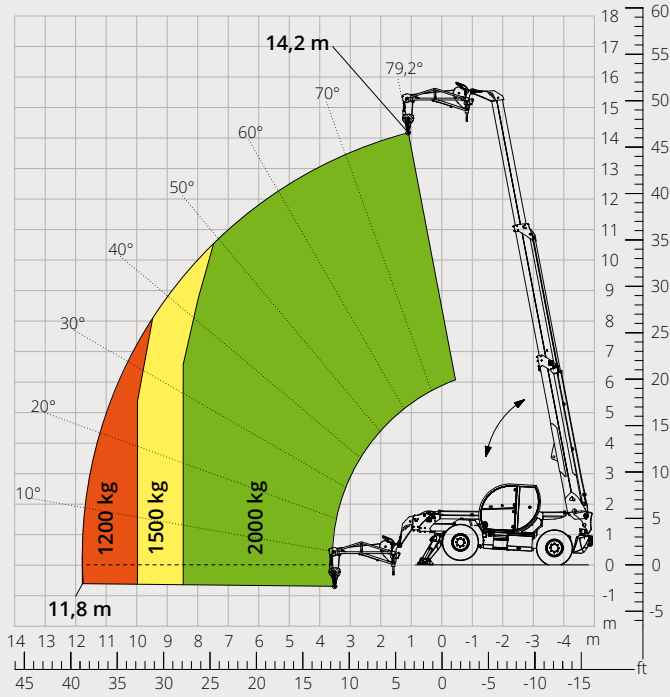

Load chart with  
**JIB WITH WINCH 3,000 kg**

ATT-04-019

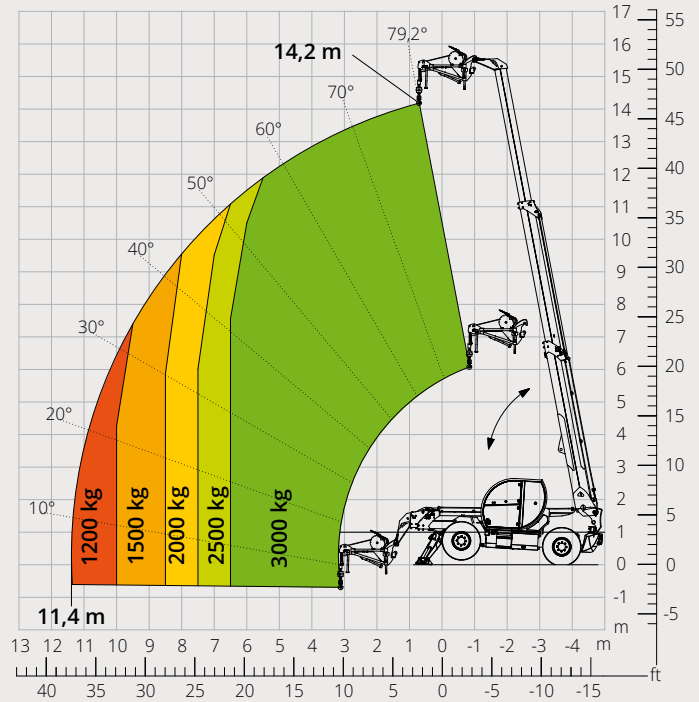

Load chart with  
**JIB 2,000 kg**

ATT-04-013

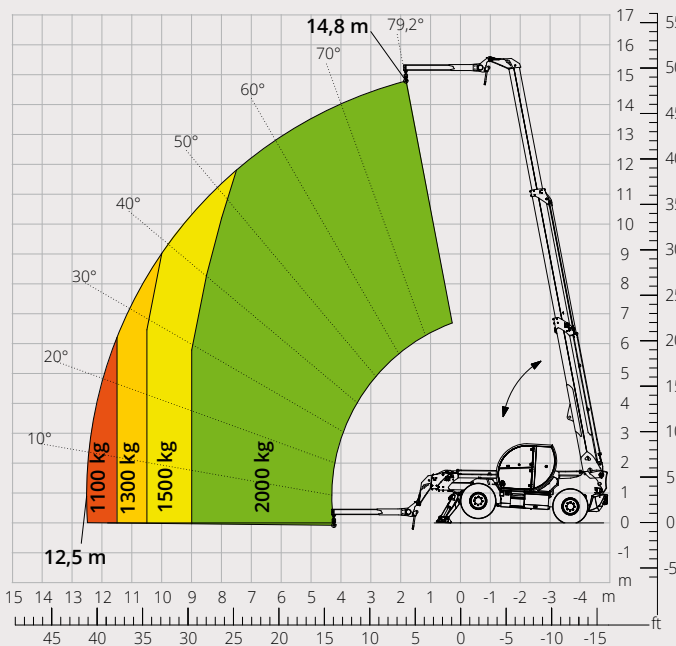

Load chart with  
**HOOK 6,000 kg**

ATT-05-001

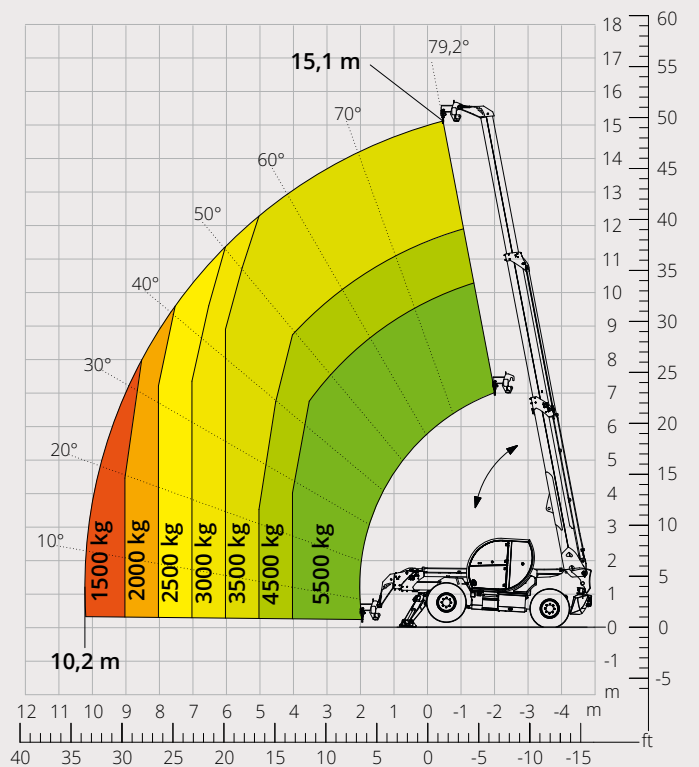

Load chart with  
**ROTATING EXTENDABLE PLATFORM**  
**500 kg**  
ATT - 01 - 007

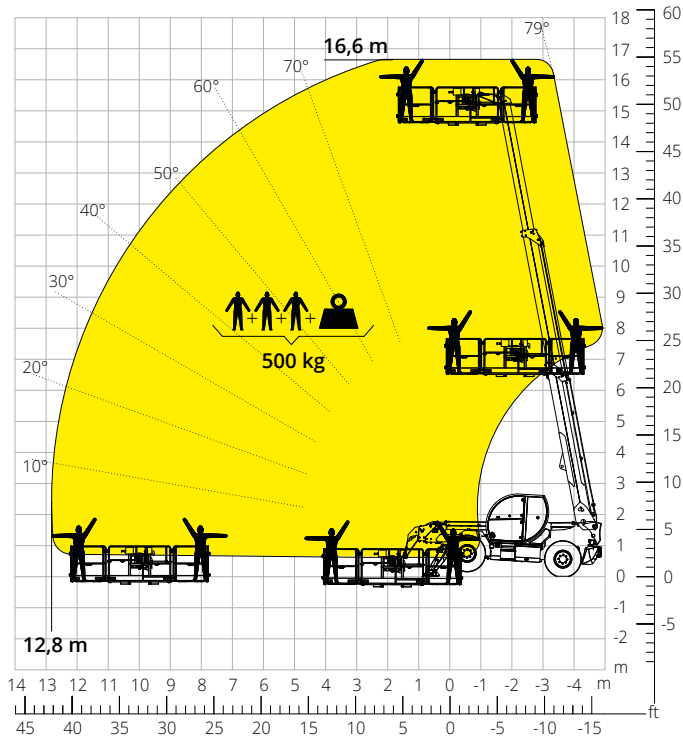

Load chart with  
**ROTATING EXTENDABLE PLATFORM**  
**1,000 kg**  
ATT - 01 - 016

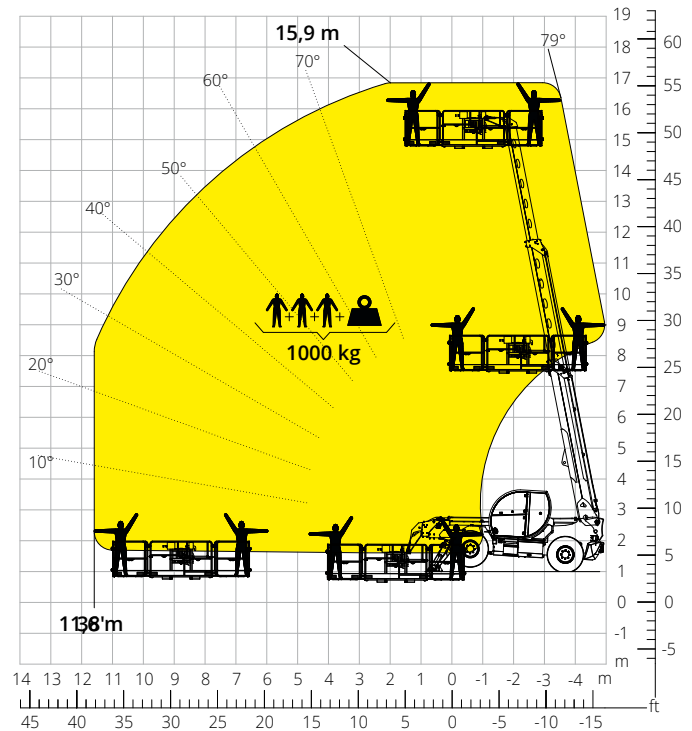

Load chart with  
**ROTATING NON-EXTENDABLE PLATFORM, 250 kg**  
ATT - 01 - 003

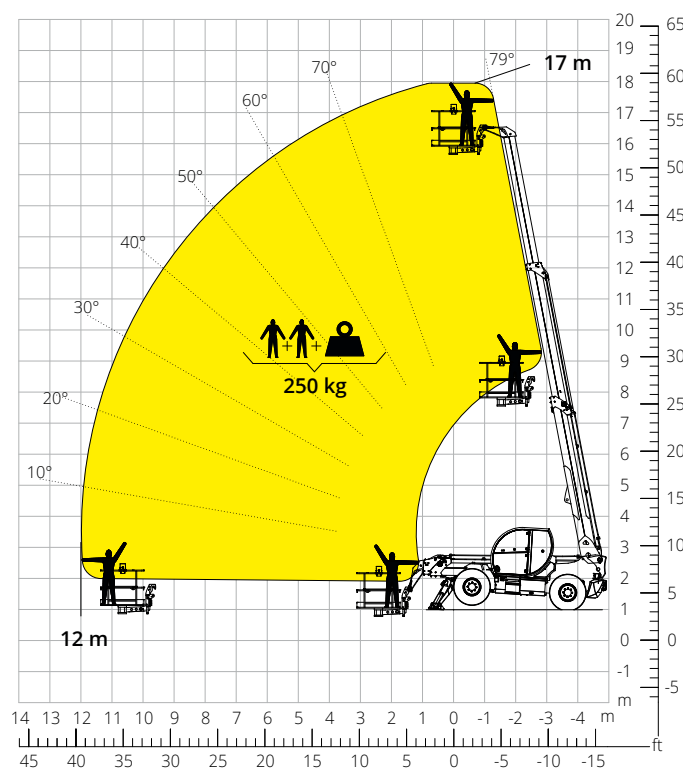

Load chart with  
**PLATFORM, 450 kg, FOR MINES**  
ATT - 01 - 027

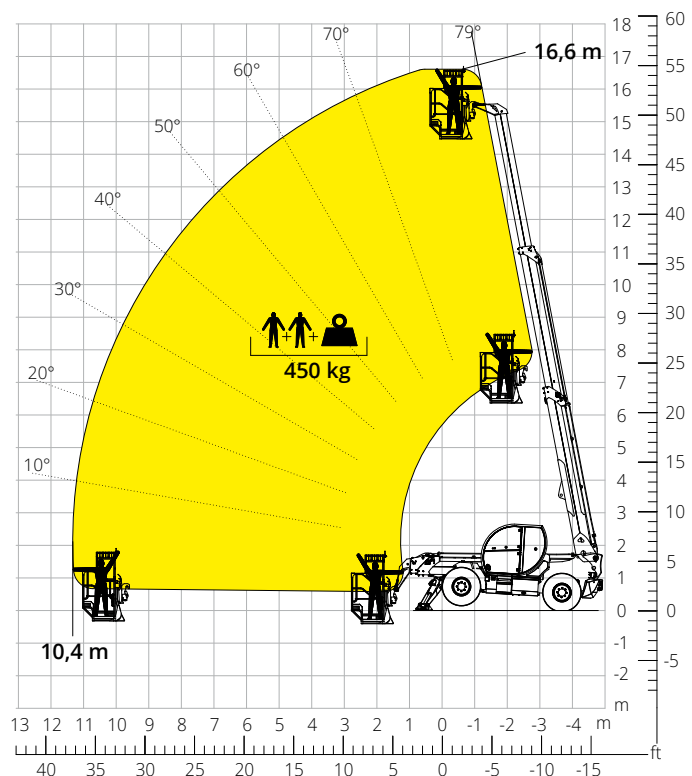

<b>Machine model</b>	Telescopic handler	TH 5,5.15 P	
	Maximum lifting capacity	5,500 kg	
	Maximum lifting height	15.20 m	
	Maximum reach	10.40 m	
<b>Stabilizer</b>	Type	Pivoting	
<b>Engine</b>	Model	<b>Deutz TCD 3,6 L4 EDG Stage IIIA</b>	<b>Deutz TCD 3,6 L4 Stage V</b>
	Rated power	74.4 kW (101.2 hp) at 2,200 rpm	
	Maximum torque	410 Nm at 1,600 rpm	
	Displacement	3,6 l	
	Cylinders	4 in line	
	Engine configuration	Turbocharged direct injection diesel	
	Cooling system	Water – intercooler	
<b>Transmission</b>	Type	Hydrostatic	
	Maximum pressure	480 bar	
	Gear box	Dropbox, 2 speeds forward-reverse	
<b>Axles and brakes</b>	Type	Axles with planetary gearboxes	
	Front axle	Oscillating and steering with levelling, +/-8°	
	Rear axle	Oscillating and steering with hydraulic lock	
	No. of driving/steering wheels	4WD - 4WS	
	Steering mode	Frontal/Concentric/Crab	
	Service brake	Wet multi-disk on front and rear axle	
	Parking brake	Hydraulic with negative action on front axle	
	Tyres dimensions	445/65 R22.5	
<b>Performance</b>	Max. travel speed	35 km/h	
	Gradeability (unladen)	57%	
	Turning radius (end of forks)	5,720 mm	
<b>Weights</b>	Total unladen*	13,000 kg	
	Front axle unladen (boom retracted and lowered)*	5,450 kg	
	Rear axle unladen (boom retracted and lowered)*	7,550 kg	
<b>Tank and system capacities</b>	Fuel tank	200 l	
	AdBlue	10 l	
	Hydraulic oil tank	93 l	
	Engine oil tank	9 l	
	Cooling liquid	20 l	
<b>Hydraulic circuit for movements</b>	Circuit type	Load sensing	
	Service pump	Variable displacement	
	Max. hydraulic flow rate	120 l/min	
	Max. boom head flow rate	75 l/min	
	Max. operating system pressure	350 bar	
	Controls for boom movements	SIL 2 electro-proportional valve	
	Movements control	1 joystick with integrated manoeuvre enable	
<b>Standard met</b>	2006/42/EC: EU Machinery Directive		
	2016/1628: EU Regulation on the emissions of stage V engines		
	EN 1459-X: Relating to standards on the safety requirements for variable reach machines		
	EN 280-1/EN 280-2: standards relating to mobile elevating work platforms (if available)		
ROPS/level 2 FOPS: relating to the standards for protective structures			

The data given in this brochure are provided for information purposes and are subject to change without prior notice.

All images are purely guideline and might not give an exact representation of the product.

\*the stated weight refers to the vehicle unladen with standard equipment and may vary depending on the chosen configuration.

The standard machine configuration includes:

## CAB

- Comfort seat with adjustable headrest
- Adjustable steering column
- Analogue joypad
- Adjustable sunblind
- Heating
- Air conditioning
- FM/AM radio with USB and Bluetooth connectivity
- Ambient LED lights
- USB Type-A and Type-C (5 V) inputs

## REAL TIME INFORMATION

- Touchscreen, 7"
- MCTS – Magni Combi Touch System on-board software
- Automatic RFID tools recognition system
- LMI – Load Moment Indicator
- LLD – Live Load Diagram
- Onboard and remote integrated diagnostics

## TECHNICAL SPECIFICATIONS

- Q-Fit standard
- Provision for platform
- Advanced three-line CAN BUS system
- Automatic levelling system for outriggers
- Automatic front and rear wheel alignment
- Automatic parking brake
- Mechanical battery cut-off in engine compartment
- Electrical system: 24 V – IP67

## SERVICE

- Warranty: 24 months/2,000 hours