

**IN**

# ES0708DC

**Paved surface scissor lift**

## LIST OF STANDARD EQUIPMENT

- Automatic pothole protection system
- Crushing protection
- High ground clearance
- Self-locking door on the platform
- Speed limit at maximum height
- Platform load sense system
- Automatic braking system
- Emergency brake release
- Non-marking tyres
- Tilt indicator with alarm
- Warning siren during lowering and dual flashing LED light
- Safety bracket for maintenance operations
- Horn
- Cylinder locking valve
- Emergency stop button
- Emergency lowering
- Traction engine protection
- Anchoring eyebolts
- Onboard diagnostics system
- Hour counter
- Proportional controls
- Fold-down guardrails
- Power to platform
- Maintenance free battery
- Explosion-proof tubing system
- Motion Alarm
- Integrated holes for fork transport
- Charging protection system
- Charging indicator
- Tie-down and lifting points
- One way platform extension deck
- Two-wheel drive
- Two-wheel steering
- Manual emergency brake release

**LOGISTICS****CONSTRUCTION**

## ES0708DC

Load capacity		230 kg
Load capacity when extended		113 kg
Max no. Occupants (Indoor/outdoor)		2/0
Working height	A	7.6 m
Platform floor level height	B	5.6 m
Overall length	C	1.52 m
Overall width	D	0.81 m
Overall height (rails up)	E	2.01 m
Transport height (rails down)	F	1.65 m
Platform dimensions (length/width)		1.37x0.7 m
Platform extension	G	0.6 m
Ground clearance (stowed)		6 cm
Ground clearance (raised)		1.5 cm
Wheelbase	H	1.13 m
Turning radius (inside)		45 cm
Turning radius (outside)		1.60 m
Driving motors		2x24VDC/0.5kW
Lifting motors		24VDC/2.2kW
Travel speed (stowed)		4 km/h
Travel speed (raised)		0.6 km/h
Batteries		24V/115Ah AGM batteries maintenance free
Integrated battery charger		24V/15A
Gradeability		25%
Maximum working slope		1.5°/3°
Non-marking tyres		230x100 mm
Weight (CE)		1,300 kg



Non-marking solid tyres



Safety bracket

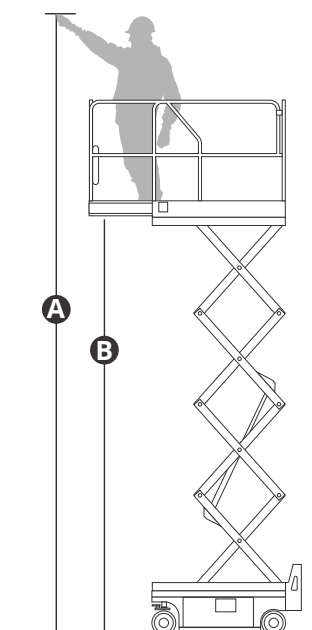
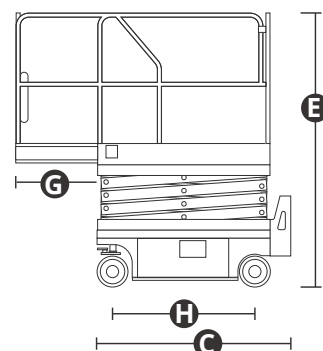
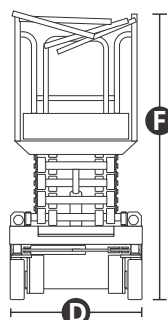

**STANDARDS MET:** EN 280-1, ANSI/SAIA A92.20

The data given in this brochure are provided for information purposes and are subject to change without prior notice. All images are purely guideline and might not give an exact representation of the product.