

# THA

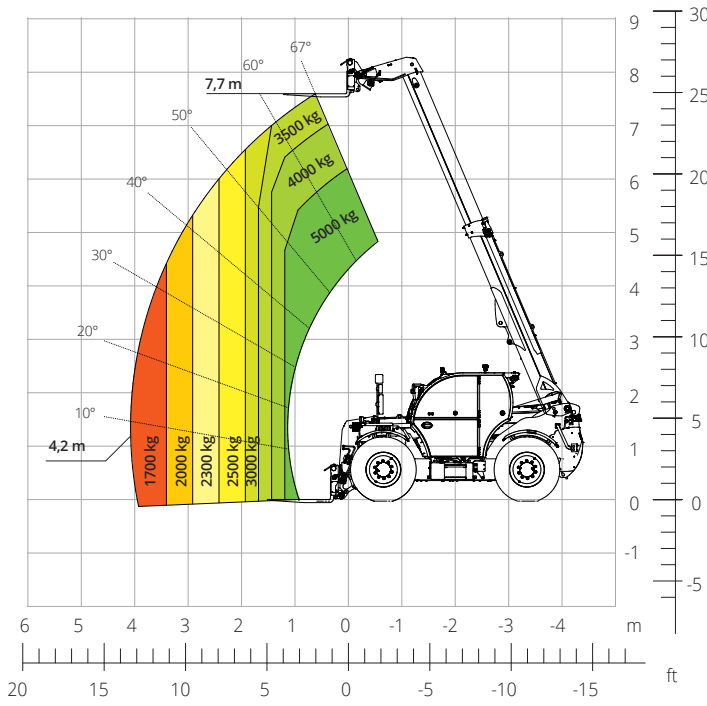

# 5.8

PRELIMINARY



AGRICULTURE

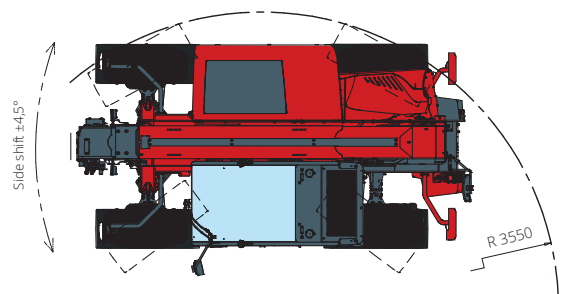
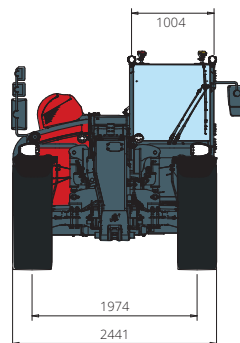
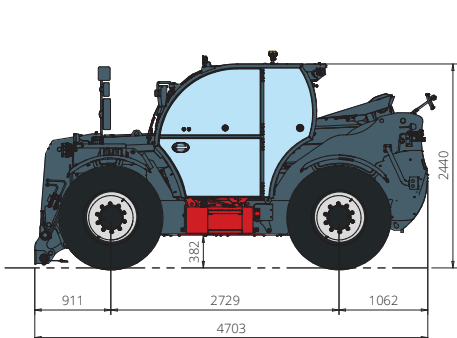

<b>Machine model</b>	Telescopic handler	THA 5.8
	Maximum lifting capacity	5,000 kg
	Maximum lifting height	7,70 m
	Maximum reach	4,20 m
<b>Engine</b>	Model	<b>FPT N45 Stage V</b>
	Rated power	125 kW (170 hp) a 2,200 rpm
	Maximum torque	712 Nm at 1,500 rpm
	Displacement	4.5 l
	Cylinders	4 in line
	Engine type	Turbocharged direct injection diesel
	Cooling system	Water – intercooler
<b>Transmission</b>	Type	CVT – 2M
	Maximum pressure	480 bar
	Gearbox	Continuously variable
<b>Axles and brakes</b>	Type	Axles with planetary gearboxes
	Front axle	Steering, oscillating only with suspensions activated with levelling, +/-7°
	Rear axle	Steering, oscillating only with suspensions deactivated with hydraulic lock
	Sideshift	±4.5°
	No. of driving wheels - steering wheels	4WD - 4WS
	Steering modes	Frontal/Concentric/Crab
	Service brake	Wet multi-disk on front and rear axle
	Parking brake	Hydraulic with negative action on front and rear axles
	Tyre sizes	460/70 R24
	<b>Performance</b>	Max. travel speed
Turning radius (over tyres)		3,550 mm
Tractive effort		10,800 daN
<b>Weights</b>	Total unladen*	9,200 kg
<b>Tank and system capacities</b>	Diesel fuel	130 l
	AdBlue	20 l
	Hydraulic fluid	130 l
	Engine oil	13,5 l
	Cooling liquid	-
<b>Hydraulic circuit for movements</b>	Circuit type	Electronic load sensing
	Service pump	Variable displacement
	Max. hydraulic flow rate	165 l/min
	Max. boom head hydraulic flow rate	100 l/min
	Max. working pressure	350 bar
	Distributor for boom movements	Electro-proportional valve
	Movements control	1 joystick with integrated manoeuvre enable
<b>Road type approval</b>	167/2013: Mother Regulation	T1b
<b>Standards met</b>	2006/42/EC: EU Machinery Directive	
	2000/14/EC: Noise Directive	
	EN 1459-1: relating to standards on the safety requirements for variable-reach trucks	
	EN 280-1: standards relating to mobile elevating work platforms (if available)	
	2014/30/EU: EMC Directive	
	ROPS/level 2 FOPS: relating to the standards for protective structures	

The data given in this brochure are provided for information purposes and are subject to change without prior notice.

All images are purely guideline and might not give an exact representation of the product.

\*the stated weight refers to the vehicle unladen with standard equipment and may vary depending on the chosen configuration.