

**TH**

**3,5.9**



CONSTRUCTION



LOGISTICS

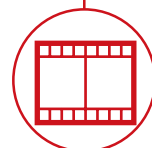

EVENTS AND  
FILM



TH  
3,5.9



**CAB**

Best-in-class  
safety and visibility



**PERFORMANCE**

Unrivalled lifting  
performance



**LOAD LIVE DIAGRAM**

Two real-time dynamic  
load charts

# TH 3,5.9

## DIMENSIONS (mm)

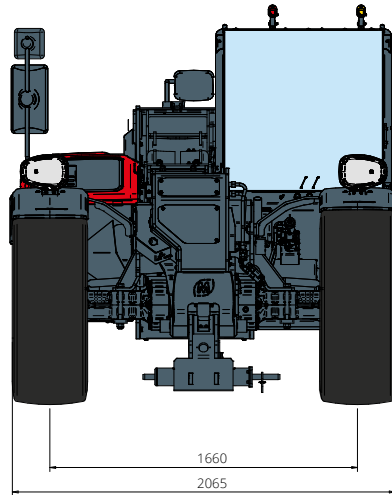

**FRONT**  
view

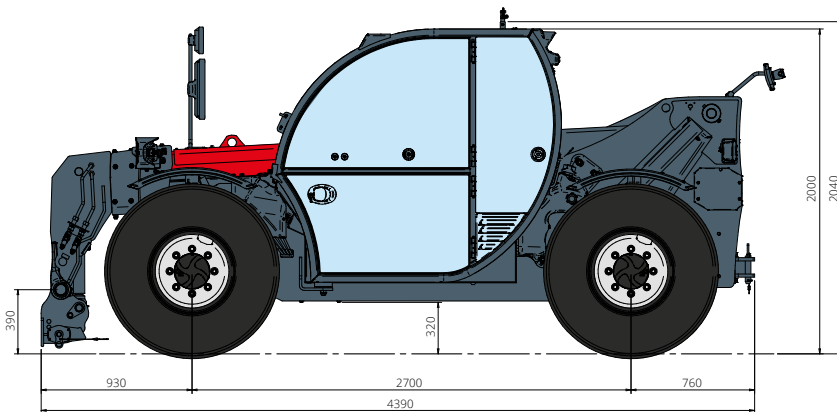

**SIDE**  
view

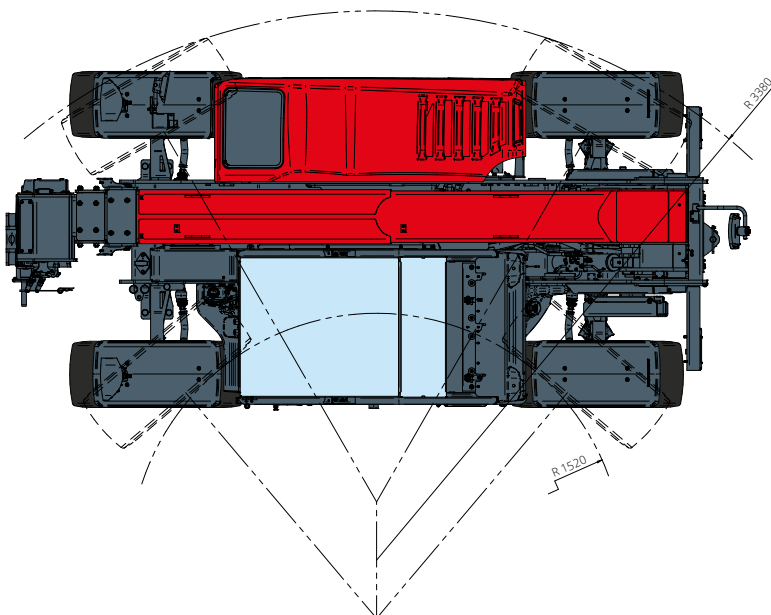

**TOP**  
view

Load chart  
**FRONT ATTACHMENT ON TYRES**

ATT-03-039

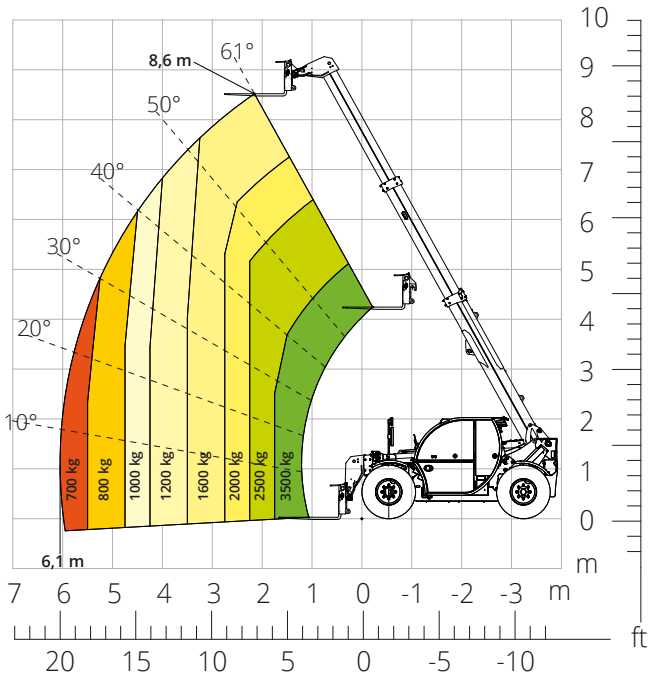

Load chart with  
**JIB, 2,000 kg**

ATT-04-013

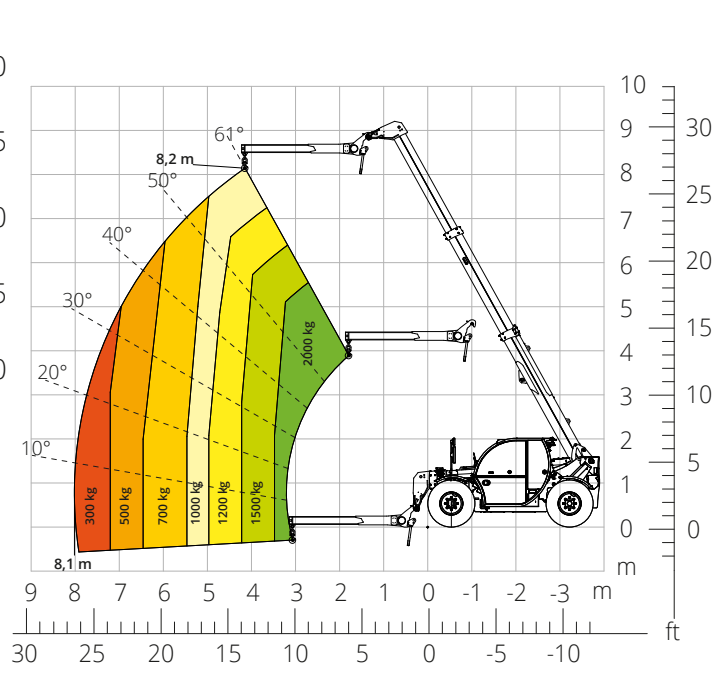

Load chart with  
**3,000 kg "SWAN NECK" JIB**

ATT-04-023

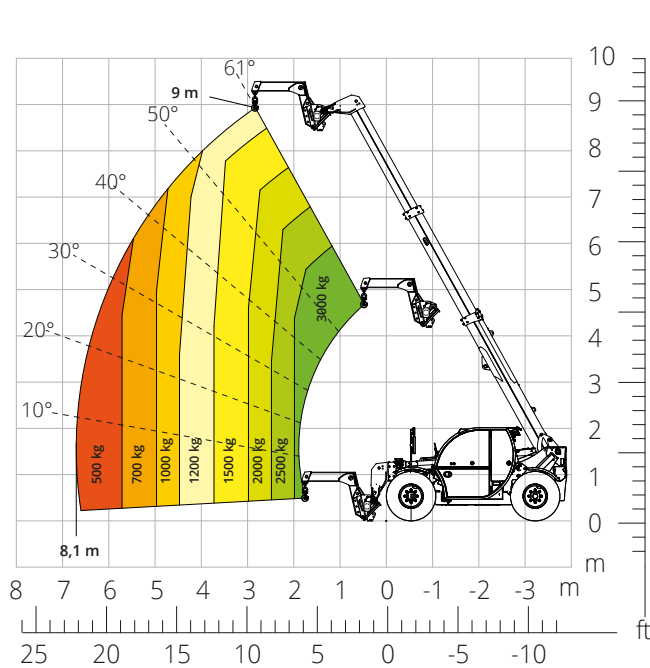

Load chart with  
**HOOK, 5,000 kg**

ATT-05-014

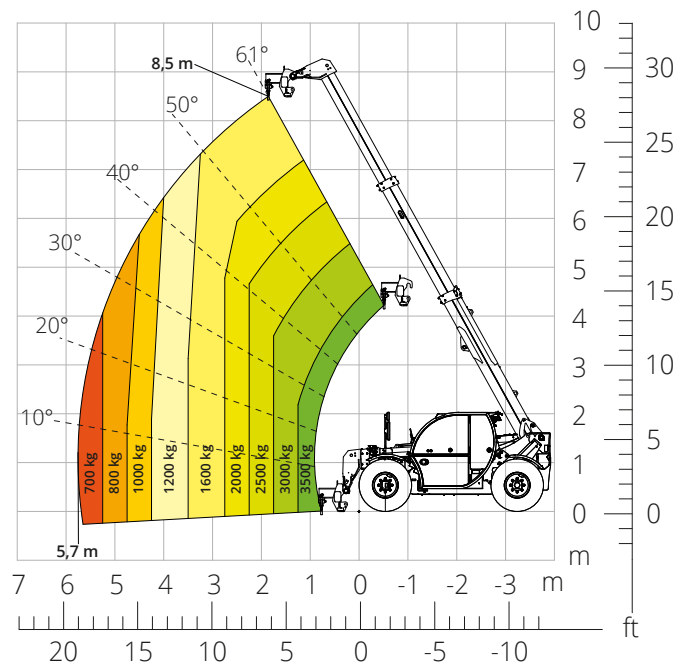

<b>Machine model</b>	Telescopic handler	TH 3,5.9	
	Maximum lifting capacity	3,500 kg	
	Maximum lifting height	8.60 m	
	Maximum reach	6.10 m	
<b>Stabilisers</b>	Type	-	
<b>Engine</b>	Model	<b>Deutz TD 2,9 L4 EDG Stage IIIA</b>	<b>Deutz TD 2,9 L4 Stage V</b>
	Rated power	55.4 kW (75.3 hp) at 2,600 rpm	
	Maximum torque	260 Nm at 1,600 rpm	
	Displacement	2.9 l	
	Cylinders	4 in line	
	Engine configuration	Turbocharged direct injection diesel	
	Cooling system	Water	
<b>Transmission</b>	Type	Hydrostatic	
	Maximum pressure	500 bar	
	Gearbox	Dropbox, 2 speeds forward-reverse	
<b>Axles and brakes</b>	Type	Axles with planetary gearboxes	
	Front axle	Steering	
	Rear axle	Free oscillation	
	No. of driving/steering wheels	4WD - 4WS	
	Steering mode	Frontal/Concentric/Crab	
	Service brake	Wet multi-disk on front and rear axle	
	Parking brake	Hydraulic with negative action on front axle	
	Tyres sizes	380/75 R20	
<b>Performance</b>	Max. travel speed	32 km/h	
	Gradeability	89%	
	Turning radius (at forks)	4,470 mm	
<b>Weights</b>	Total unladen*	7,300 kg	
<b>Tank and system capacities</b>	Diesel Fuel	75 l	
	AdBlue	-	
	Hydraulic oil tank	95 l	
	Engine oil	9 l	
	Coolant	15 l	
<b>Hydraulic circuit for movements</b>	Circuit type	Load sensing	
	Service pump	Variable displacement	
	Max. hydraulic flow rate	90 l/min	
	Max. boom head flow rate	75 l/min	
	Max. operating system pressure	315 bar	
	Controls for boom movements	Compensated electro-proportional valve	
	Movements control	1 joystick with integrated manoeuvre enable	
<b>Standard met</b>	2006/42/EC: EU Machinery Directive 2016/1628: EU Regulation on the emissions of stage V engines EN 1459-X: Relating to standards on the safety requirements for variable reach machines EN 280-1: standards relating to mobile elevating work platforms (if available) ROPS/FOPS level 2: relating to the standards for protective structures		

The data given in this brochure are provided for information purposes and are subject to change without prior notice.

All images are purely guideline and might not give an exact representation of the product.

\*the stated weight refers to the vehicle unladen with standard equipment and may vary depending on the chosen configuration.

The standard machine configuration includes:

## CAB

- Comfort seat
- Adjustable steering wheel
- Adjustable sunblind
- Heating

## REAL TIME INFORMATION

- Touchscreen, 7"
- MCTS – Magni Combi Touch System on-board software
- LMI – Load Moment Indicator
- Onboard and remote integrated diagnostics

## TECHNICAL SPECIFICATIONS

- Q-Fit standard
- Advanced two-line CAN BUS system
- Automatic front and rear wheel alignment
- Automatic parking brake
- External battery cut-off
- Electrical system: 12 V – IP67

## SERVICE

- Warranty: 24 months/2,000 hours