

TH 3.6



CONSTRUCTION



LOGISTICS

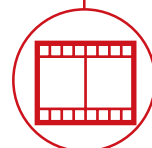

EVENTS AND
FILM



DIMENSIONS (mm)

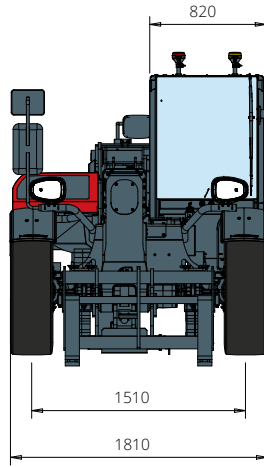

FRONT
view

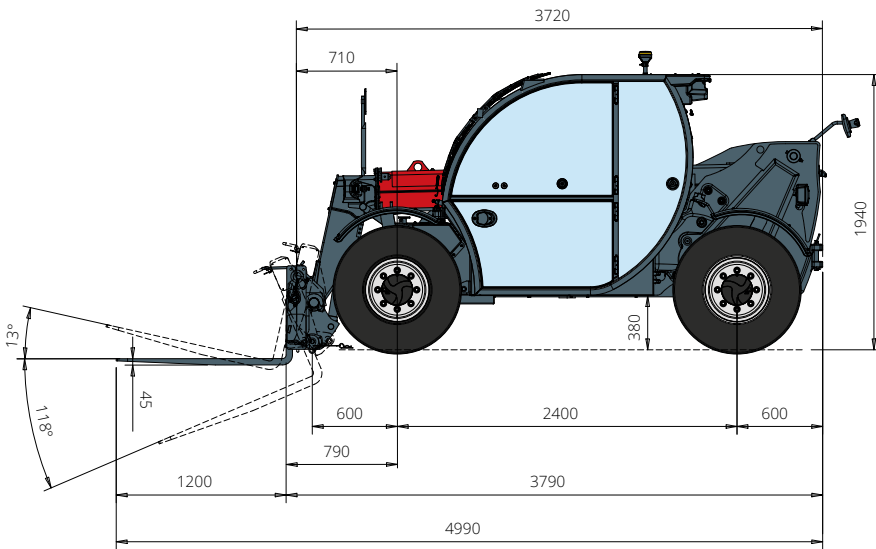

SIDE
view

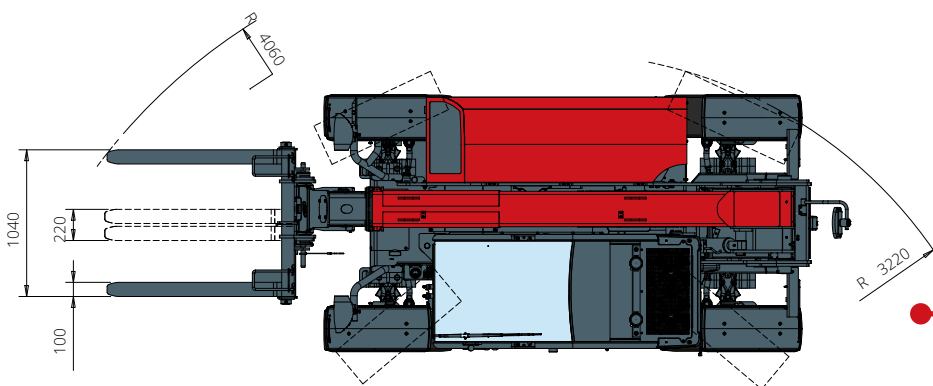

TOP
view

Load chart with
FEM FORK CARRIAGE 3,000 kg

ATT 03-016

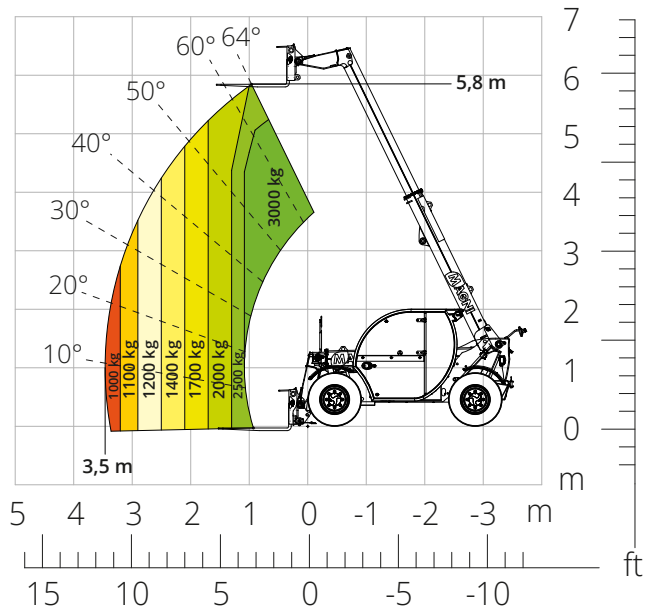

Load chart with
HOOK, 3,000 kg

ATT-05-004

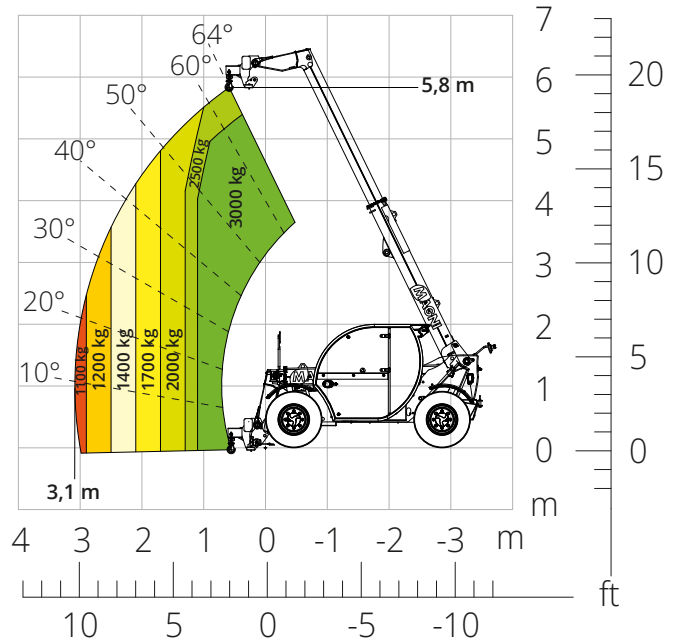

Load chart with
**FEM FORK CARRIAGE 2,500 kg,
SIDE TIPPING - FOR EMPTYING BINS**

ATT-03-054

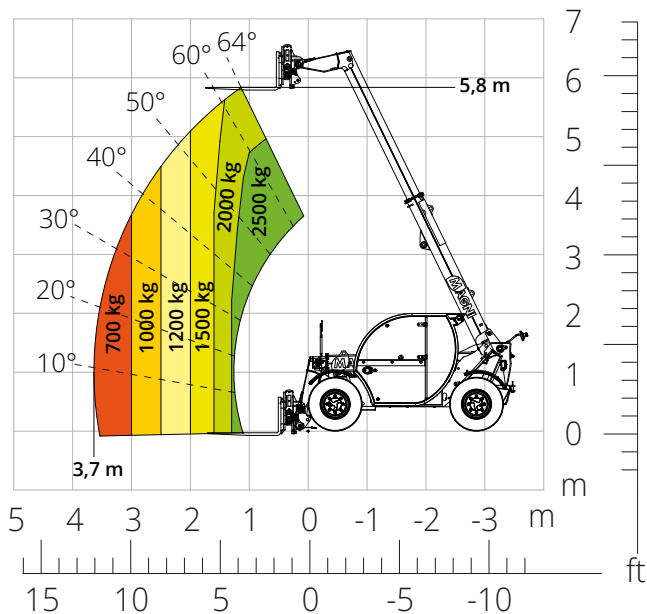

Load chart with
FIXED PLATFORM, 250 kg

ATT-01-002

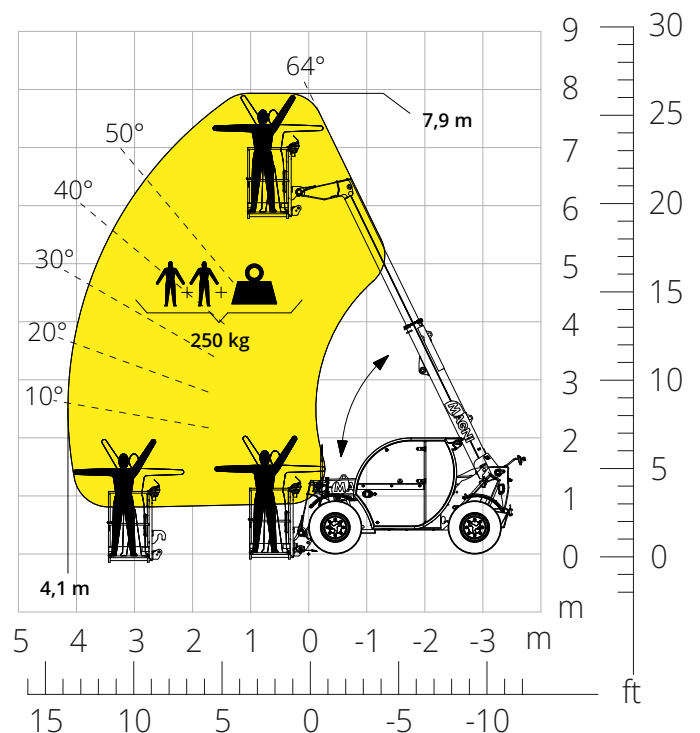

TH
3.6



CAB

Best-in-class
safety and visibility



PERFORMANCE

Unrivalled lifting
performance



LOAD LIVE DIAGRAM

Two real-time dynamic
load charts

Machine model	Telescopic handler	TH 3.6	
	Maximum lifting capacity	3,000 kg	
	Maximum lifting height	5.80 m	
	Maximum reach	3.20 m	
Stabilizer	Type	-	
Engine	Model	Deutz TD 2,9 L4 EDG Stage IIIA	Deutz TD 2,9 L4 Stage V
	Rated power	55.4 kW (75.3 hp) at 2,600 rpm	
	Maximum torque	260 Nm at 1,600 rpm	
	Displacement	2.9 l	
	Cylinders	4 in line	
	Engine configuration	Turbocharged direct injection diesel	
	Cooling system	Water	
Transmission	Type	Hydrostatic	
	Maximum pressure	500 bar	
	Gear box	Direct drive 2 speed	
Axles and brakes	Type	Axles with planetary gearboxes	
	Front axle	Steering	
	Rear axle	Free oscillation	
	No. of driving/steering wheels	4WD - 4WS	
	Steering mode	Frontal/Concentric/Crab	
	Service brake	Wet multi-disk on front axle	
	Parking brake	Hydraulic with negative action on front axle	
	Tyres dimensions	12.0/75 R18	
Performance	Max. travel speed	35 km/h	
	Gradeability (unladen)	83%	
	Turning radius (end of forks)	4,060 mm	
Weights	Total unladen*	4,850 kg	
Tank and system capacities	Fuel tank	65 l	
	AdBlue	-	
	Hydraulic oil tank	85 l	
	Engine oil tank	9 l	
	Cooling liquid	15 l	
Hydraulic circuit for movements	Circuit type	Gear pump	
	Service pump	Fixed displacement	
	Max. hydraulic flow rate	87 l/min	
	Max. boom head flow rate	75 l/m	
	Max. operating system pressure	255 bar	
	Controls for boom movements	Electro-proportional valve	
	Movements control	1 joystick with integrated manoeuvre enable	
Standard met	2006/42/EC: EU Machinery Directive		
	2016/1628: EU Regulation on the emissions of stage V engines		
	EN 1459-X: Relating to standards on the safety requirements for variable reach machines		
	EN 280-1: standards relating to mobile elevating work platforms (if available)		
	ROPS/FOPS: relating to the standards for protective structures		

The data given in this brochure are provided for information purposes and are subject to change without prior notice.

All images are purely guideline and might not give an exact representation of the product.

*the stated weight refers to the vehicle unladen with standard equipment and may vary depending on the chosen configuration.

The standard machine configuration includes:

CAB

- Air suspension comfort seat
- Adjustable steering column
- Adjustable sunblind
- Heating
- USB Type-A and Type-C (5 V) inputs

REAL TIME INFORMATION

- Touchscreen, 7"
- MCTS – Magni Combi Touch System on-board software
- LMI – Load Moment Indicator
- Onboard and remote integrated diagnostics

TECHNICAL SPECIFICATIONS

- Q-fit type 2 standard
- Advanced two-line CAN BUS system
- Automatic front and rear wheel alignment
- Automatic parking brake
- External battery cut-off
- Electrical system: 12 V – IP67

SERVICE

- Warranty: 24 months/2,000 hours